

UPLIFT V2 Standing Desk

F500 (T-Frame)

Specifications

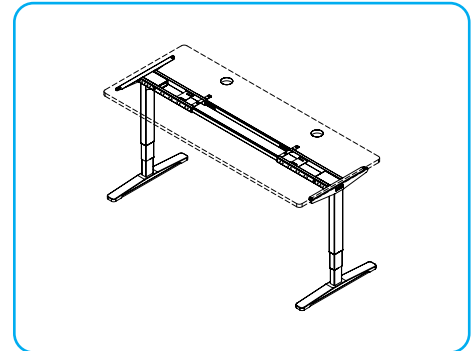
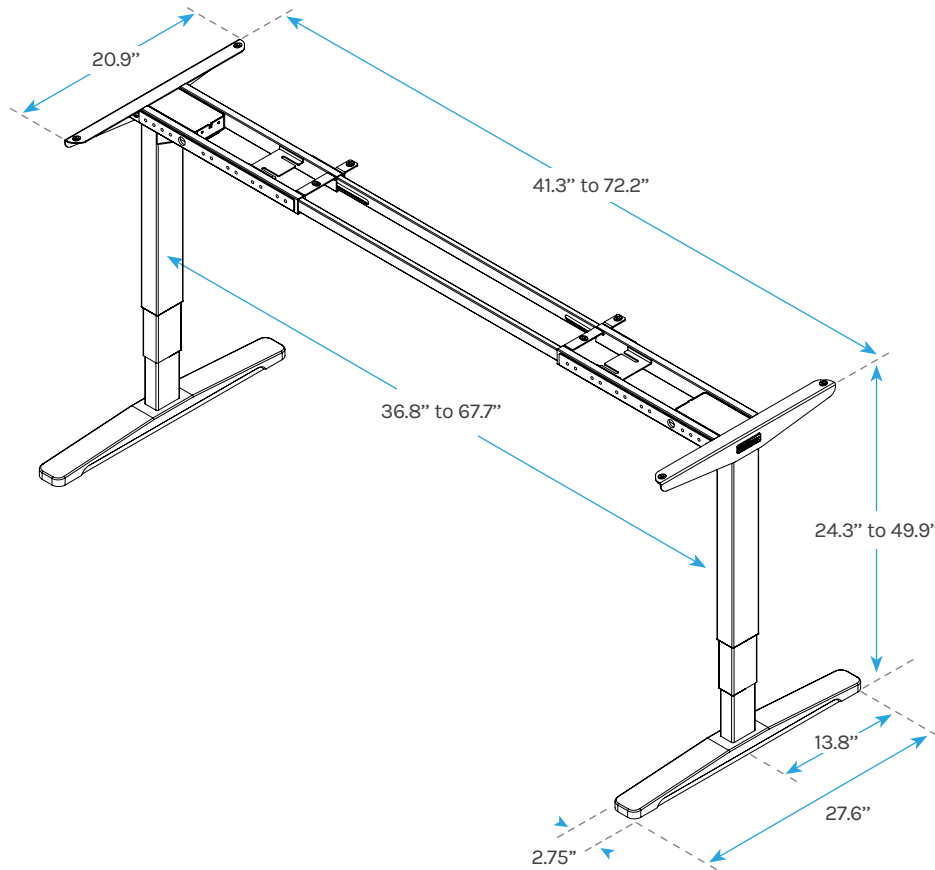

Pictured: frame and desktop placement



**Contract-grade
Quality**

Warranty	15 year warranty on all UPLIFT Desk products. upliftdesk.com/warranty/
Height Range	24.3"-49.9"
Travel Speed	2" per second
Noise Level	<48 dB
Lifting Capacity	355 lbs
Input Voltage	100-240V
Output Power	400W
Standby Power Consumption	0.1 W
UL Listing	US & Canada



Award winning desk frame



Patented frame mounting points



15 year warranty



Dual motor design with 355 lb lifting capacity



33% faster & 33% greater height range than 2-stage legs



Stability brace on each Leg



Superior anti-collision sensitivity



Improved stability with 33% larger, precision tolerance legs



Free wire management included



41.3" - 72.2" width adjustment



Energy efficient & whisper quiet



Meets BIFMA X5.5-2021 Durability Standard

Copyright Notice: This guide is a component of this UPLIFT Desk product. This guide is a part of the scope of delivery, even if the item is resold. This guide is also available on the UPLIFT Desk website: upliftdesk.com. These specifications are subject to United States copyright law.