

V2 Standing Desk

F500 (T-Frame)

Specifications

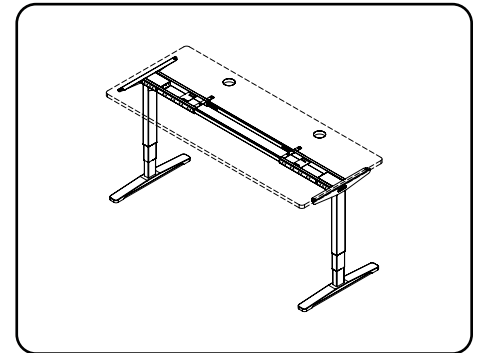
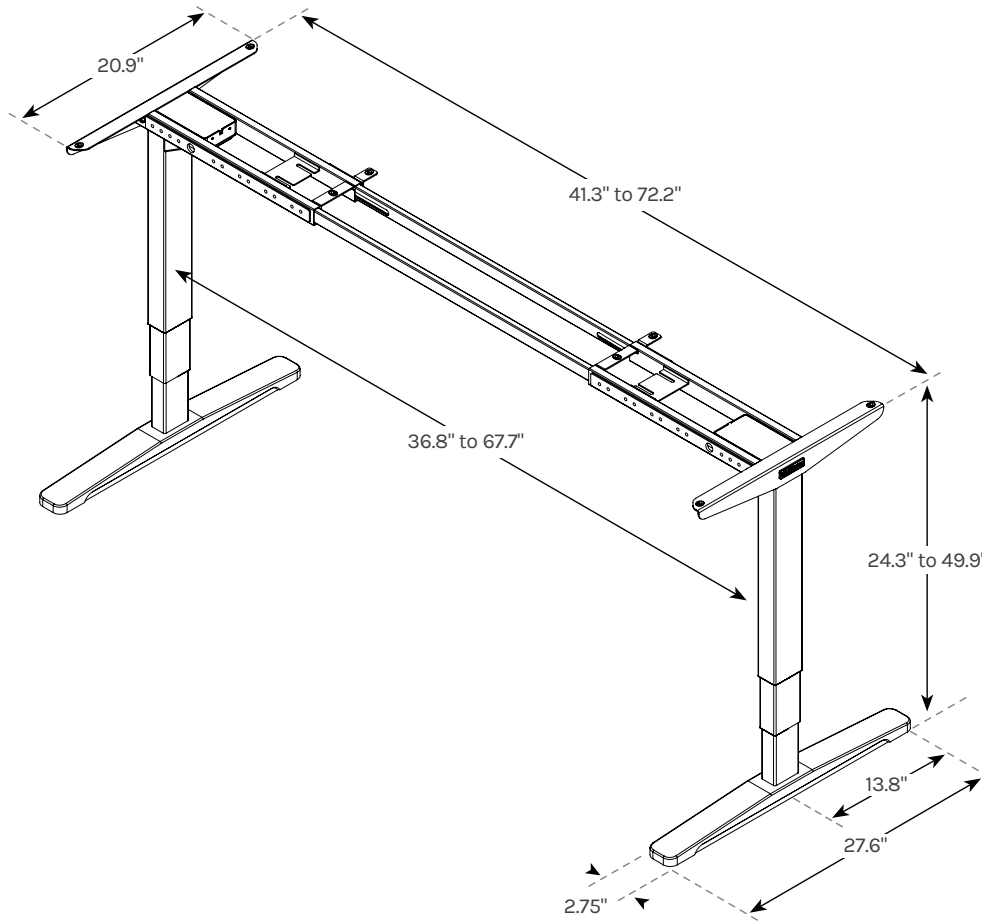

Pictured: frame and desktop placement



**Contract-grade
Quality**

Warranty	15 year warranty on all UPLIFT Desk products. upliftdesk.com/warranty/
Height range	24.3"-49.9"
Travel speed	2" per second
Noise level	<48 dB
Lifting capacity	355 lbs
Input voltage	100-240V
Output power	400W
Standby power consumption	0.1W
UL listing	US & Canada



Award winning desk frame



Superior anti-collision sensitivity



Patented frame mounting points



Improved stability with 33% larger, precision tolerance legs



15 year warranty



Free wire management included



Dual motor design with 355 lb lifting capacity



41.3" - 72.2" width adjustment



33% faster & 33% greater height range than 2-stage legs



Energy efficient & whisper quiet



Stability brace on each Leg



Meets ANSI/BIFMA X5.5 2021 Desk & Table Products standard for safety, durability, and structural performance

Copyright Notice: This guide is a component of this UPLIFT Desk product. This guide is a part of the scope of delivery, even if the item is resold. This guide is also available on the UPLIFT Desk website: upliftdesk.com. These specifications are subject to United States copyright law.