

V2 L-Shaped Standing Desk

F550 - F551

UPLIFT DESK
Work Better. Live Healthier

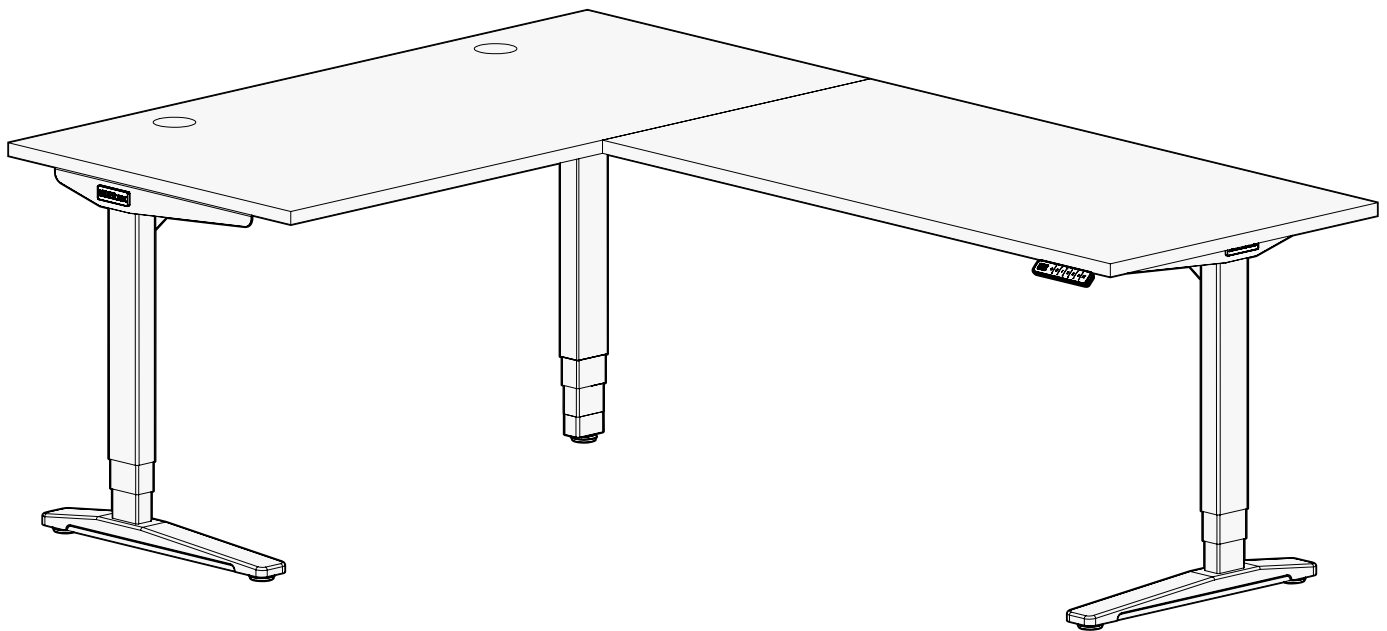

Two person
assembly

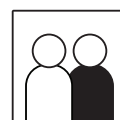

Scan QR code for
product webpage



For assembly assistance, visit upliftdesk.com/contact, call 800-349-3839, or email support@upliftdesk.com
©2023 UPLIFT Desk®. All Rights Reserved. US patent no. 11,109,672 B2

Safety and Warnings



WARNING: Read all instructions before assembly. Failure to assemble or operate the desk properly may result in damage or personal injury. Retain this manual for future reference or owners.



WARNING: Keep fingers and body parts clear of the moving desk edges. Check the desk's surroundings on all sides before raising or lowering the desk to ensure there are no obstacles that can be damaged or damage the desk.



WARNING: Ensure all desk and accessory cords have enough slack so they don't pull as the desk moves up and down.



WARNING: Keep children away from the desk unless supervised. Misuse of the desk can cause personal injury. If children cannot be supervised at all times, use the desk's safety lock feature or remove the power cord to prevent its operation. Safety lock feature only available with Advanced Keypads.



WARNING: The desk is designed for use in dry indoor environments only. Use of desk outdoors or in damp locations will damage the desk and can cause risk of electric shock, fire, or personal injury.



WARNING: Only plug the desk into a properly grounded 100-240V power outlet. Using a voltage converter is considered improper use and can cause damage to the desk.



WARNING: Do not open or insert any object into any desk frame component such as the legs or control box. Doing so may cause damage and can cause risk of electric shock.



WARNING: In case of spilled liquid on any electrical desk component, disconnect the desk from the power outlet immediately. Clean up the spill with a dry cloth and plug the desk back into the power outlet. There is a risk of desk failure or electric shock if desk components become wet.



WARNING: Never use the desk if the power cord or plug becomes damaged as this can cause a risk of fire and electric shock. Contact UPLIFT Desk for a replacement power cord if it is damaged in any way.



WARNING: Risk of serious injury or death. Adjusting the height of the desk can pinch or crush body parts trapped between the desktop and stationary objects. Do not place feet or other body parts on any items located under the desk other than on approved items such as foot rests and desk mats.



WARNING: Be sure there is a gap of at least 1" between the moving parts of the standing desk and objects located next to it to avoid pinch and crush hazards. Move the desk through its full range of motion to ensure the 1" gap is maintained above, below, and all around the desk.



WARNING: Persons with limited mental or physical capabilities who are unable to comprehend the safe operation of the height adjustability feature must be supervised and must not operate the desk.



WARNING: Inspect the desk regularly and stop using immediately if you notice any damaged or loose parts. Only replace damaged desk parts with authorized UPLIFT Desk parts.





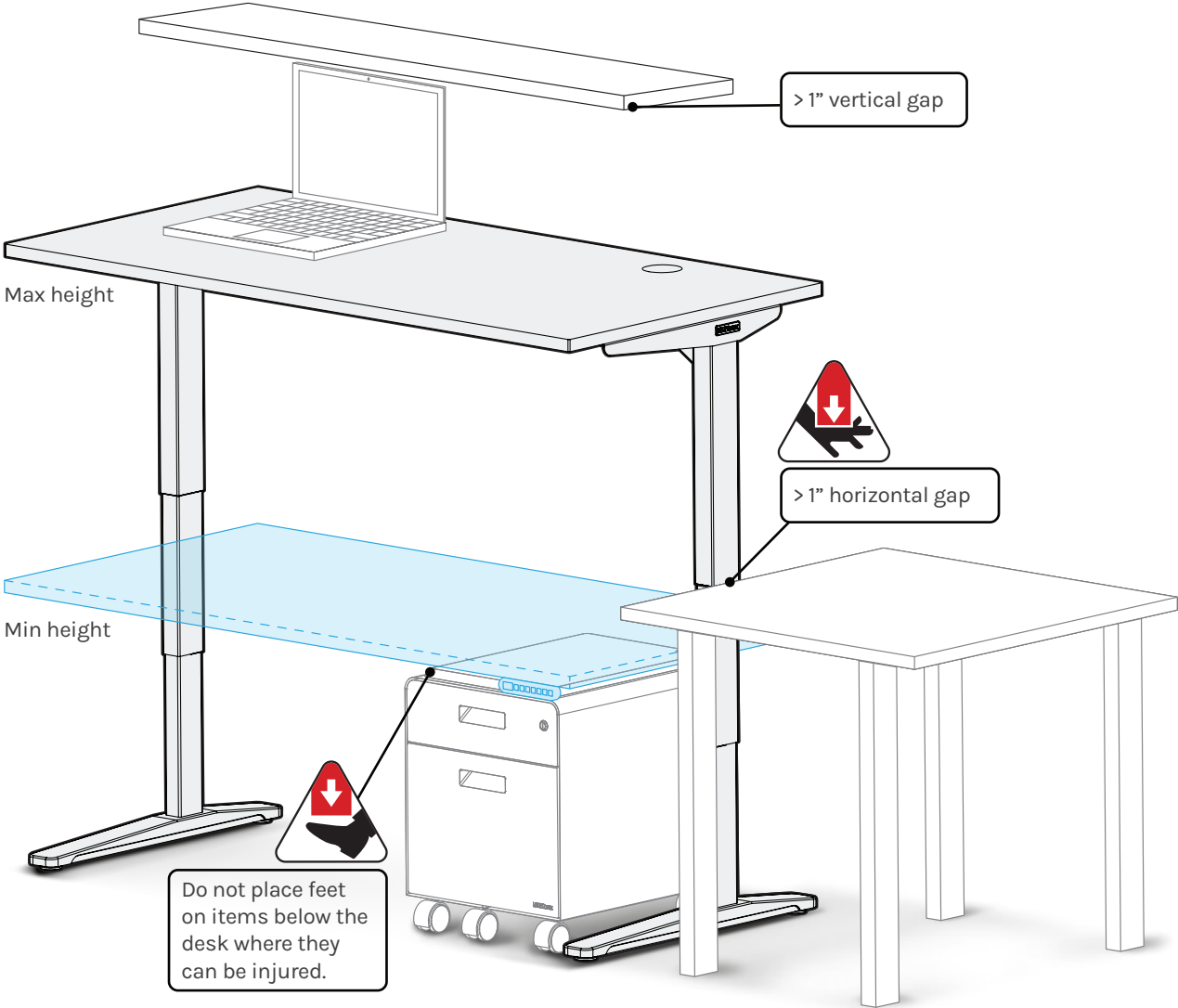

Please read these instructions carefully. This desk is height adjustable to fit the user's height. Inappropriate use of this desk can cause property damage and/or bodily injury. Under no circumstances does the manufacturer accept warranty or liability claims for damages caused from improper use of this desk. Please provide these instructions to any new user or owner of the desk.

Note: Desk image is for reference only and may not match your desk style.

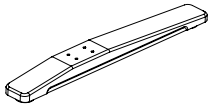

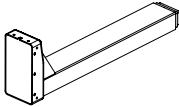
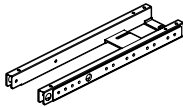
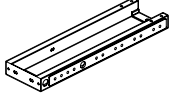
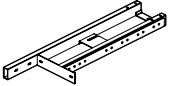
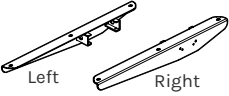
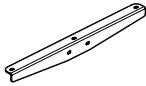

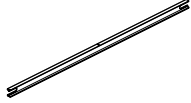
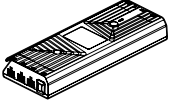
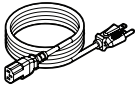
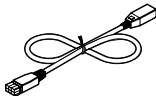
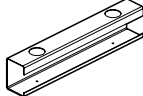







Package Contents

Frame Components (ships in multiple boxes)

P1 Foot qty 2 	P2 Peg Foot 	P3 Leg qty 3 	P4 Crossbar End qty 2 	P5 Short Corner Crossbar End 	P6 Long Corner Crossbar End 
P8 Side Bracket qty 2  Left Right	P10 Corner Side Bracket 	P11 Anchor Plate qty 2 	P12 Crossbar Rail qty 4 	P14 Keypad <div style="border: 1px solid black; padding: 5px; text-align: center;">Type varies</div>	P15 Control Box 
P16 Power Cable 	P17 Leg Extension Cable qty 3 (2 short & 1 long) 	P18 Wire Management Tray 	P19 Logo Plate qty 2 		

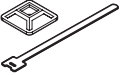
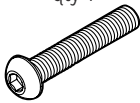
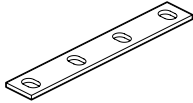
Hardware Components

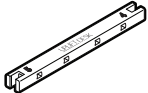
H1 M6 x 10 Screw qty 18 	H2 M6 x 14 Machine Screw qty 12 	H3 M8 x 8 Set Screw qty 16 	H4 a #10 x 3/4" Wood Screw qty 25 	H4 b #10-24 x 3/4" Machine Screw qty 13 
H5 Washer qty 13 	H6 4mm Allen Wrench 	H7 M8 x 10 Machine Screw qty 4 	H8 5mm Allen Wrench 	H9 Cable Mount qty 15 
H10 M6 x 35 Machine Screw qty 4 	H11 Support Bracket qty 3 	H14 #10 x 5/8" Wood Screw qty 4 	H15 Allen Wrench Handle 	

You'll also need

Phillips Head Screwdriver

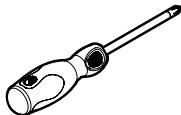

Parts Diagram

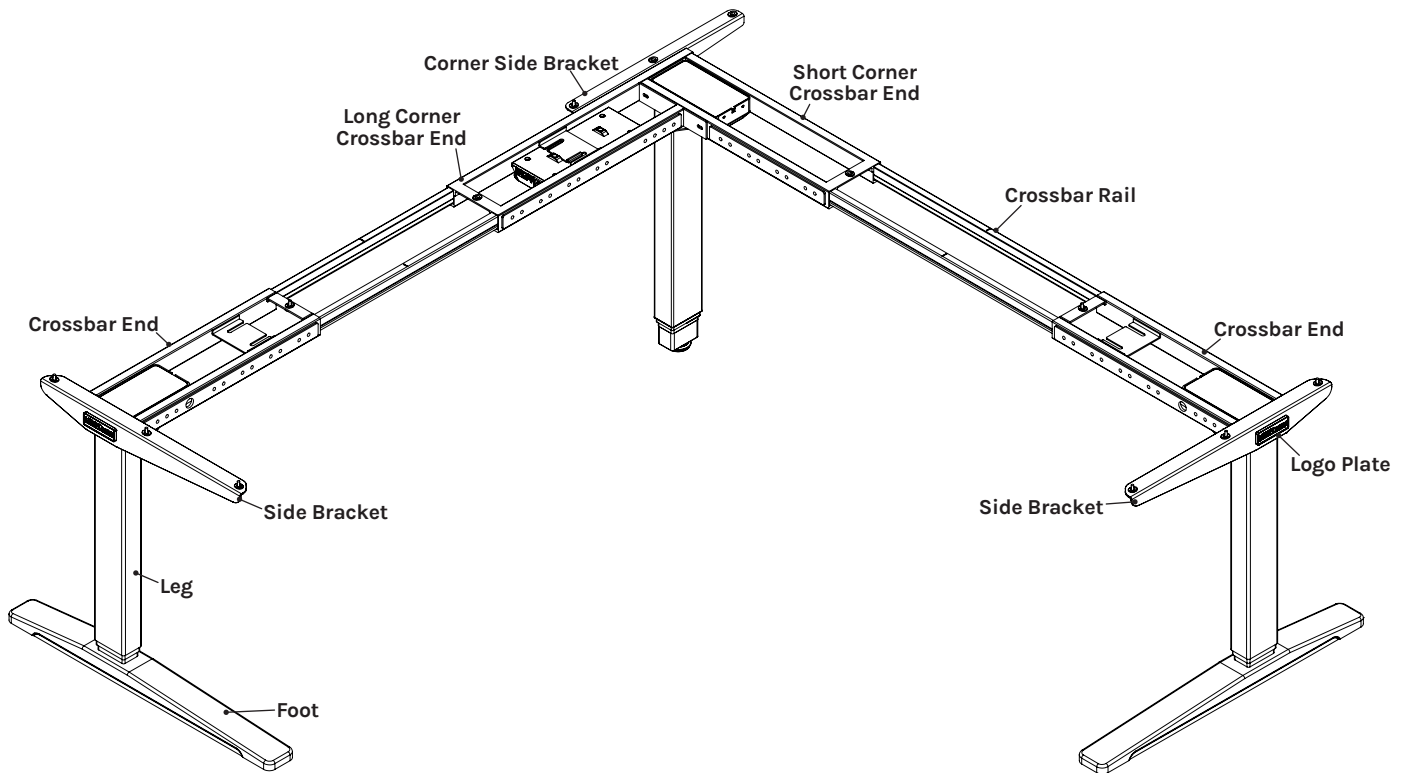

Step 1 - Inventory of Parts

- A. To avoid damage to your floor or desktop, assemble the desk on a clean carpet or blanket.
- B. Lay out all parts from each box and ensure you have everything listed in the package contents of this manual before throwing away any packaging.

If a part is missing, please triple check that the part isn't in a box. Check boxes very thoroughly by removing all packaging; check every nook and cranny. If the part is still missing, call (800) 349-3839 or email support@upliftdesk.com before beginning assembly.

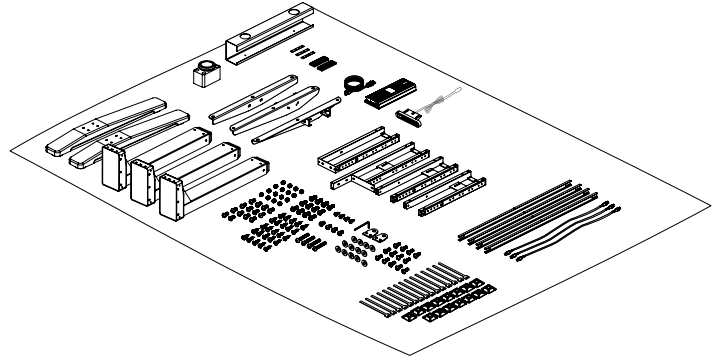

Outside Leg Assemblies (qty 2)

Step 2 - Attach Crossbar Ends

- A. Position a Crossbar End (**P4**) as shown.
- B. Position a Leg (**P3**) so that the back of the Leg is flush with the back of the Crossbar End.
- C. Use the 4mm Allen Wrench (**H6**) to loosely start four M6 x 10 Machine Screws (**H1**) through the holes in the sides of the Crossbar End and into the threaded holes in the sides of the Leg.
- D. Tighten the screws with the Allen Wrench.
- E. Repeat this step with a second Leg and Crossbar End.

IMPORTANT: Ensure that all screws are tight before proceeding.

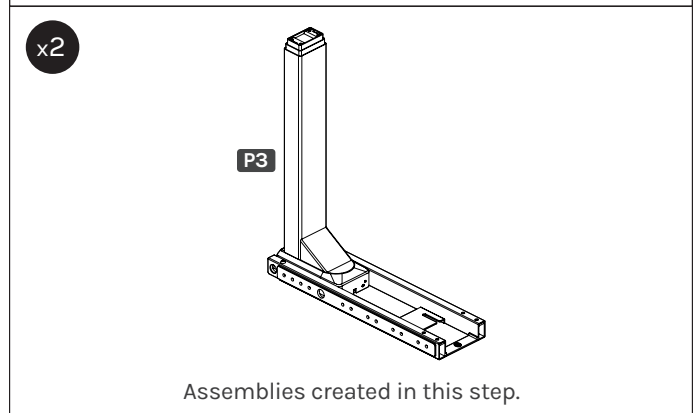
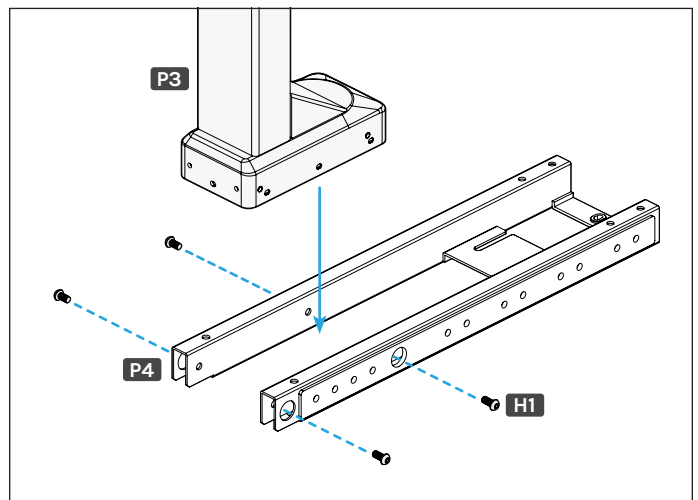

Step 3 - Attach Left and Right Side Brackets

- A. Position the Right Side Bracket (**P8**) as shown and insert the tabs into the openings at the back of the Crossbar End.
- B. Loosely start two M6 x 10 Machine Screws (**H1**) through the holes in the top of the Crossbar End and into the threaded holes in the top of the Side Bracket tabs.

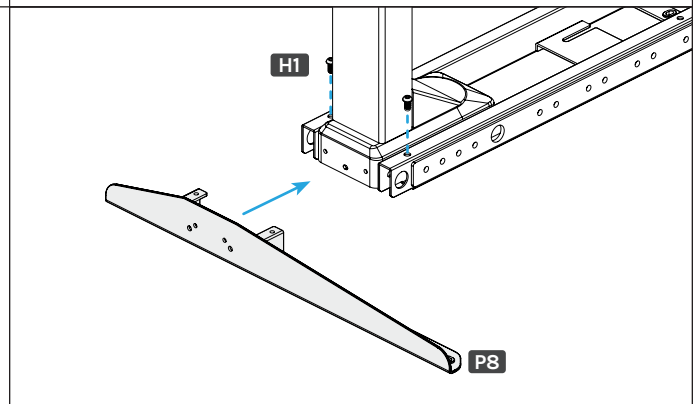

- C. Loosely start two more M6 x 10 Screws through the two larger holes in the face of the Side Bracket and into the threaded holes in the back of the Leg.
- D. Tighten all four screws with the 4mm Allen Wrench (**H6**).
- E. Repeat the previous steps to attach the Left Side Bracket.

IMPORTANT: Ensure that all screws are tight before proceeding.

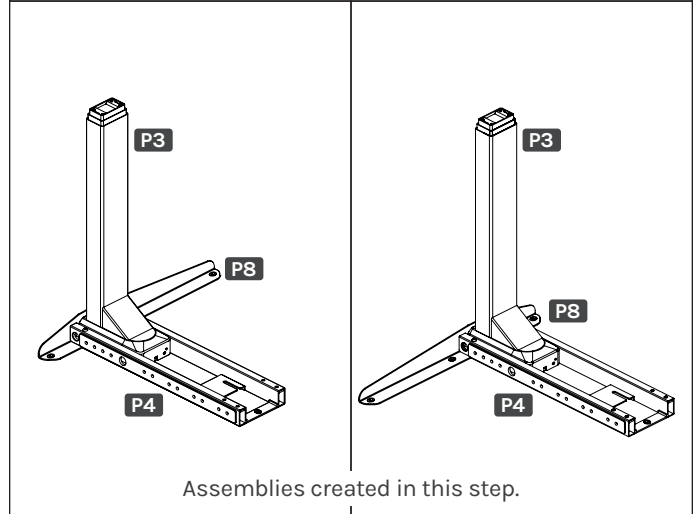
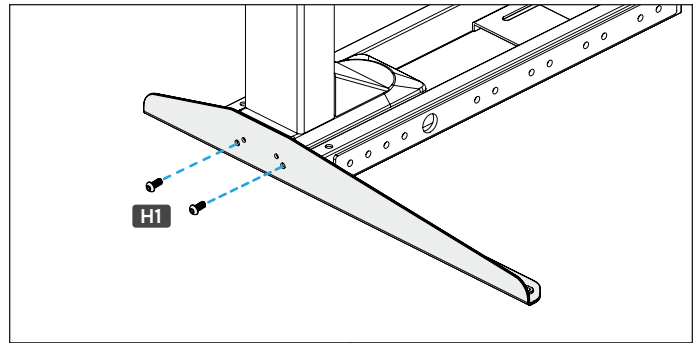

Step 4 - Attach Logo Plates

- A. Align the posts on the back of a Logo Plate (**P19**) with the two smaller holes in the face of the Side Bracket. The Logo Plate should be upside down at this point.
- B. Firmly press the Logo Plate posts all the way into the holes, concealing the two screws.
- C. Repeat the previous steps to attach the second Logo Plate.

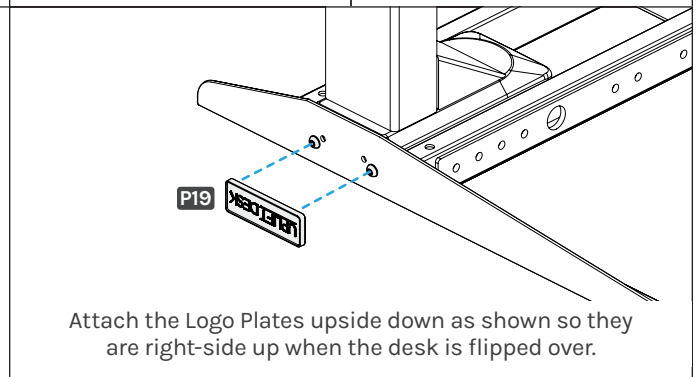

Step 5 - Attach Feet

- A. When attaching the feet to the outside legs, make sure the long ends of the Feet are facing in the same direction as the long ends of the Side Brackets. Place one of the Feet (**P1**) on top of one of the Legs as shown and align the four holes in the Foot with the four threaded holes in the end of the Leg.
- B. Loosely insert four M6 x 14 Screws (**H2**) through the holes in the Foot and into the threaded holes in the Leg, but don't tighten them until all four screws have been started.
- C. Tighten screws using the 4mm Allen Wrench (**H6**) attached to the Allen Wrench Handle (**H15**) to provide more leverage when tightening screws.

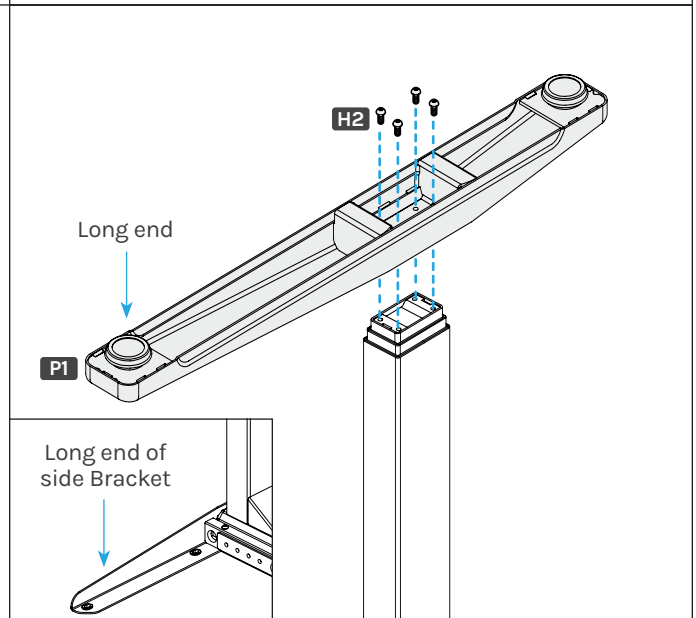

IMPORTANT: Tighten Foot screws very thoroughly to ensure the stability of the desk.

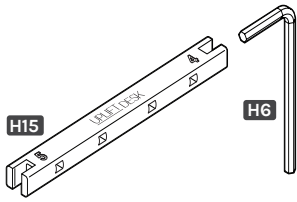

- D. Repeat the previous steps to attach the second Foot. Tighten screws very thoroughly.

IMPORTANT: Retighten each screw again to ensure that all screws are **VERY** tight before proceeding. Tightening these screws has a noticeable impact on desk stability.

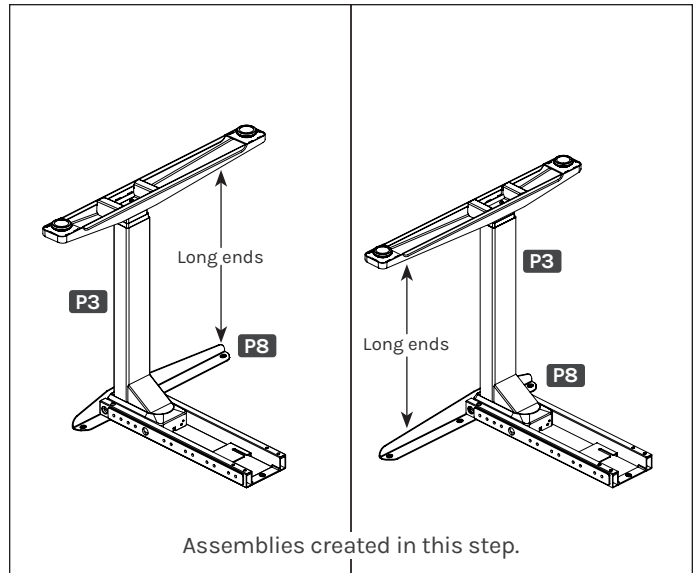

Corner Leg Assembly

Step 6 - Attach Short Corner Crossbar End

- Position the Short Corner Crossbar End (**P5**) as shown.
- Position the third Leg (**P3**) inside of the Short Corner Crossbar End so that the back of the Leg is flush against the backplate of the Short Corner Crossbar End.
- Use the 4mm Allen Wrench (**H6**) to loosely start two M6 x 10 Screws (**H1**) through the Short Corner Crossbar End and into the threaded holes in the side of the Leg **ONLY** on the side shown.

Do not tighten the screws yet.

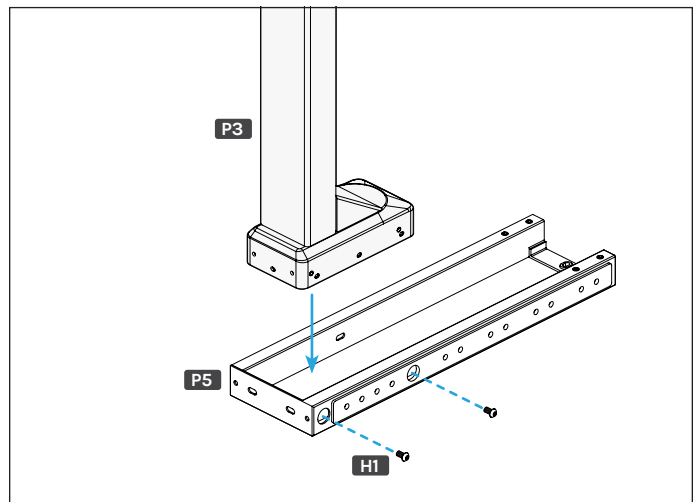

Step 7 - Attach Long Corner Crossbar End

- Position the Long Corner Crossbar End (**P6**) as shown around the Short Corner Crossbar End and Leg.
- Use the 4mm Allen Wrench to loosely start two M6 x 35 Screws (**H10**) through the two holes shown in the Long Corner Crossbar End, through the Short Corner Crossbar End, and into the threaded holes in the side of the Leg.

Do not tighten the screws yet.

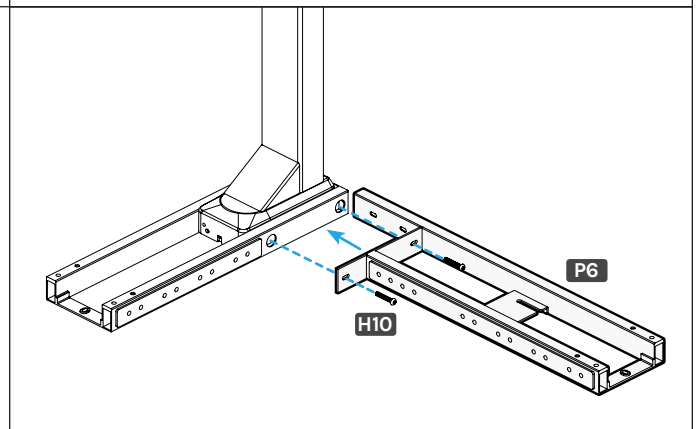

Step 8 - Attach Corner Side Bracket

- Position the Corner Side Bracket (**P10**) as shown against the Long Corner Crossbar End (**P6**).
- Use the 4mm Allen Wrench to loosely start the remaining two M6 x 35 Screws (**H10**) through the Side Bracket, both Crossbar Ends, and into the threaded holes in the back of the Leg.
- Tighten all the screws started in the previous three steps.

IMPORTANT: Ensure that all screws are tight before proceeding.

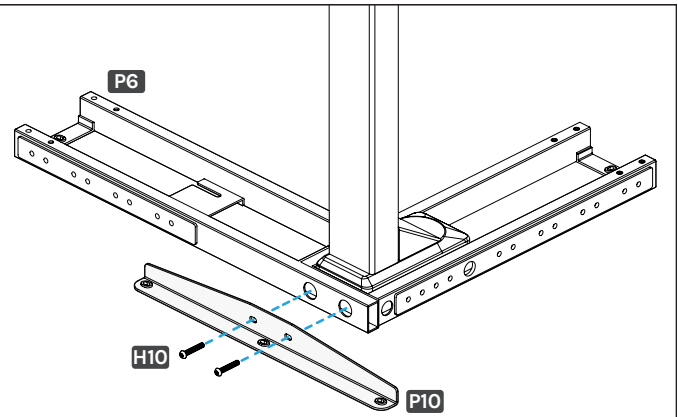

Step 9 - Attach Peg Foot

- Place the Peg Foot (**P2**) on the Leg as shown and align the four holes in the Foot with the four threaded holes in the end of the Leg.
- Loosely insert four M6 x 14 Screws (**H2**) through the holes in the Foot and into the threaded holes in the Leg, but don't tighten them until all four screws have been started.
- Tighten screws using the 4mm Allen Wrench (**H6**) attached to the Allen Wrench Handle (**H15**).

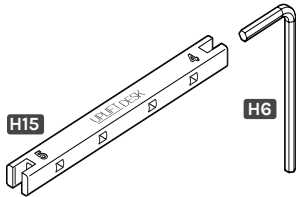

IMPORTANT: Tighten Foot screws very thoroughly to ensure the stability of the desk.

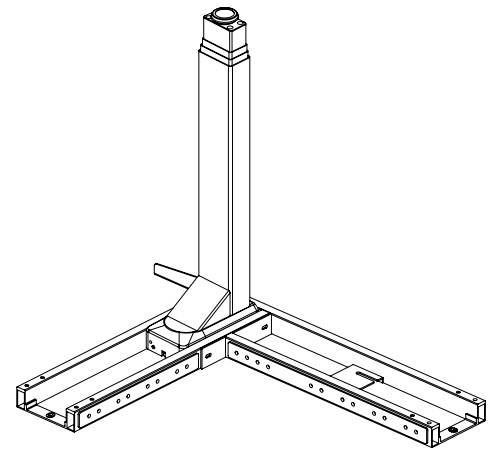
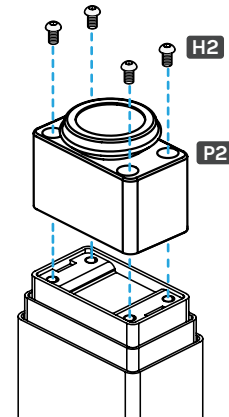

Completed center Leg assembly.

Step 10 - Insert Crossbar Rails into Right Leg Assembly

- A. Insert a Crossbar Rail (**P12**) into each of the two openings at the end of the Crossbar End (**P4**) of the right Leg assembly shown.
- B. Slide the Crossbar Rails as far as they will go into the Crossbar End.

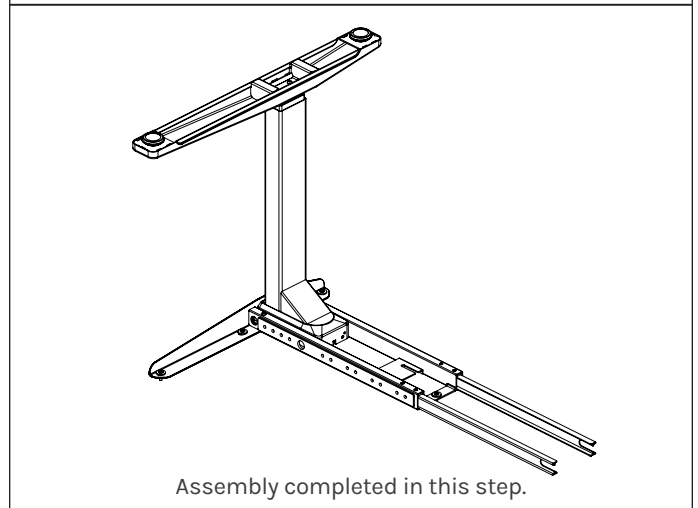
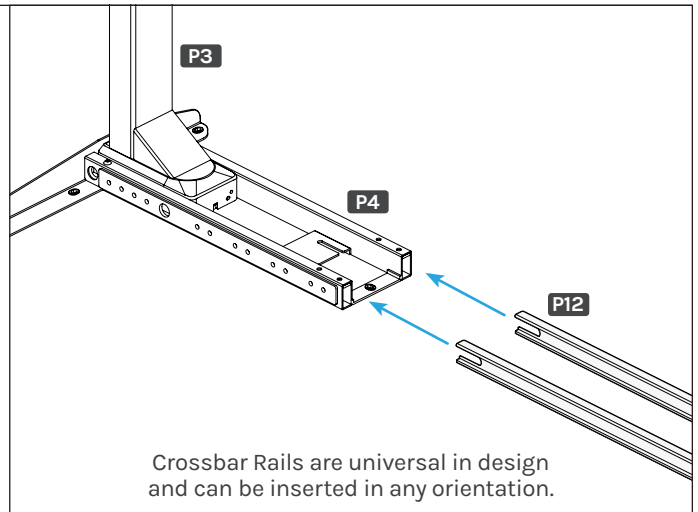

Step 11 - Slide Corner Leg Assembly onto Crossbar Rails

- A. Position the corner Leg assembly as shown next to the Crossbar Rails inserted in the previous step.
- B. Slide the corner Leg assembly on to the Crossbar Rails as far as it will go.

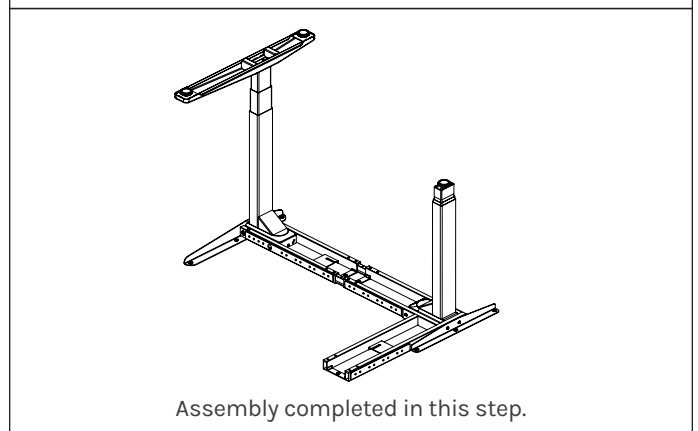
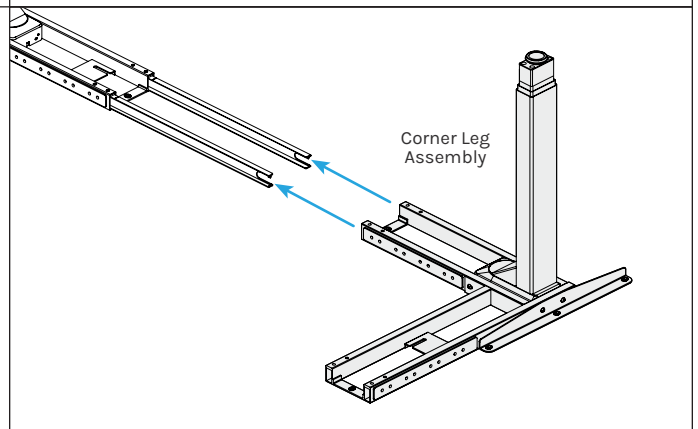

Step 12 - Arrange Main & Return Desktops

UPLIFT L-shaped desktops allow the return to be placed on either side (except custom solid wood desktops, which are made to order with the return machined for the side specified when ordered). Before attaching the frame to the desktops, determine if you are building the desk with the return on the right side (Right return) or with the return on the left side (Left return).

The return is typically located on the side of your dominant hand. For example, if you are right handed it is recommended that you locate the return on the right side. However, whether you have the return on the left or the right side is up to you and the needs of your workspace.

Left return

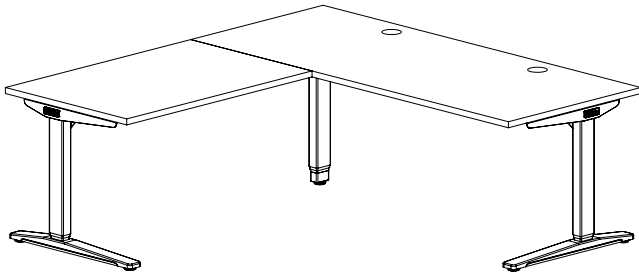

Right return

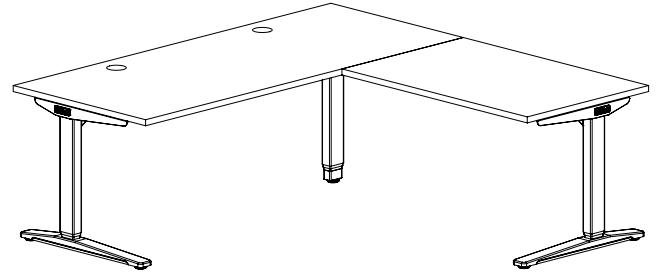

Using a clean blanket or carpeted area to avoid damage to your desktops, lay down the desktops with the pre-drilled holes facing up. Then arrange them in either the right or left return upside-down orientation shown below. Remember that the return will be located on the opposite side once the desk is flipped over.

Bottom surface of desktops
arranged for a **left return**.

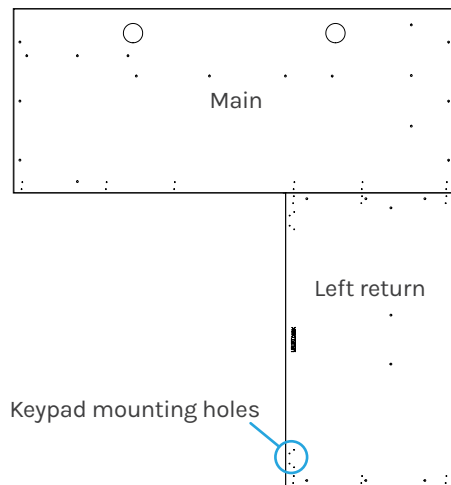

Bottom surface of desktops
arranged for a **right return**.

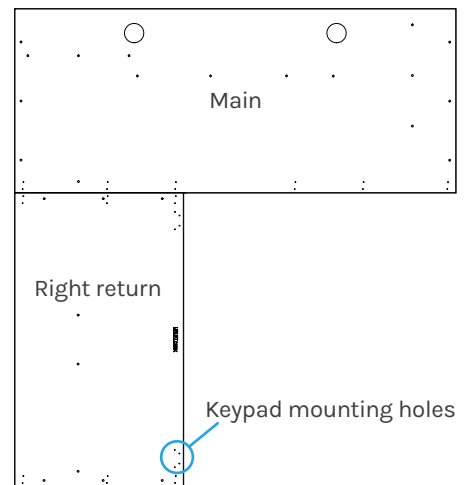

Step 13 - Place Leg Assemblies from Step 11 onto Desktops

Leg assemblies are positioned on the main and return desktops in the same orientation regardless of whether the return will be on the left or right side.

- A. With the help of a friend, pick up and place the Leg assemblies from Step 11 onto the desktops as shown below for either the right or left return orientation. Lift the frame (do not slide it) to align the holes in the Side Brackets and Crossbar Ends with the holes in the desktop. Lifting the frame prevents scratching the desktop and keeps the rubber grommets (shown) in the frame from coming out. If any rubber grommets are dislodged, simply reinsert them in the orientation shown in the image.

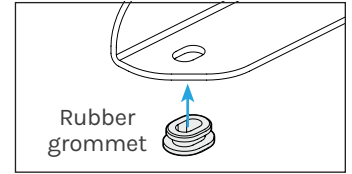

- B. Adjust the locations of the right Leg assembly and corner Leg assembly so the holes in the Side Brackets and Crossbar Ends align with the pre-drilled holes in the desktop.

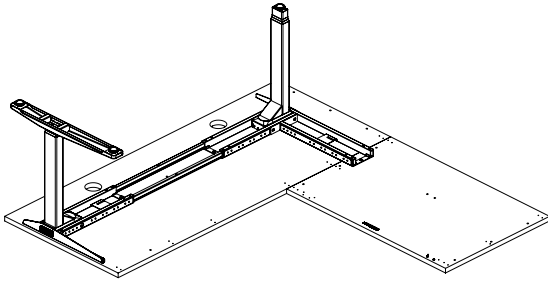

Desk with **left return**.

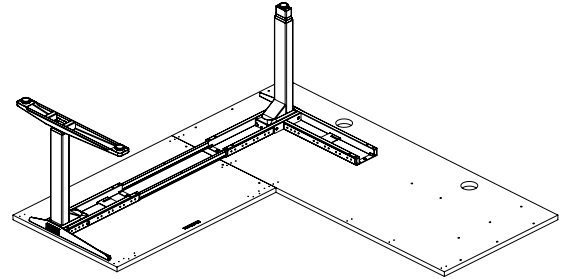

Desk with **right return**.

Step 14 - Attach Leg Assemblies to Desktops

- A. L-shaped main and return desktops will have either metal threaded inserts or drilled pilot holes for the attachment of the frame. See below to select the correct screws needed to attach the Leg assemblies to the desktops.

For desktops that have metal threaded inserts, use the #10-24 x 3/4" Screws (**H4b**) and Washers (**H5**).

Machine screw: flat end **H4b** 

For desktops that do not have metal threaded inserts, use the #10 x 3/4" Wood Screws (**H4a**) and Washers (**H5**).

Wood screw: pointy end **H4a** 

- B. Use a Phillips Screwdriver to insert a Screw (**H4a or H4b**) with Washer (**H5**) through each of the holes shown in the Side Brackets and Crossbar Ends and into the pre-drilled holes or metal threaded inserts in the desktops. For left returns, wait to install the return side screw shown in the diagram below.

Do not tighten the screws until all have been started. Be sure not to over tighten to avoid stripping.

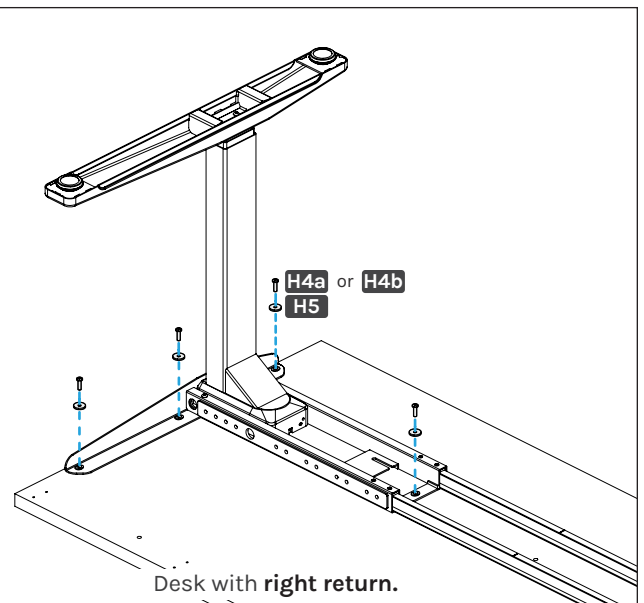
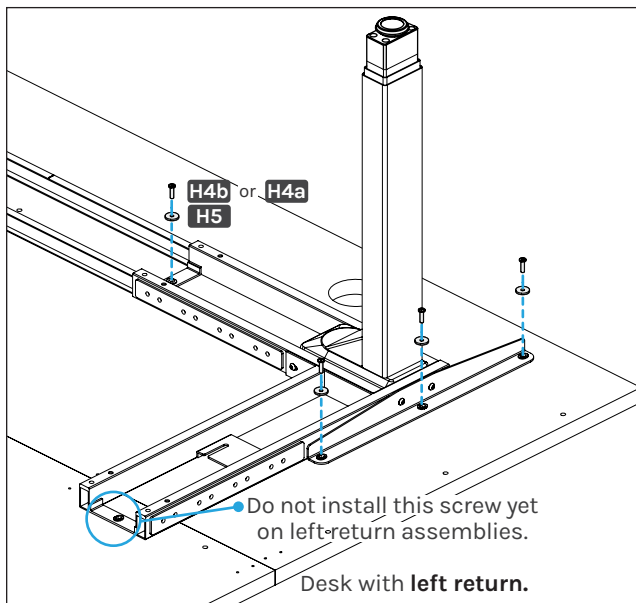

Step 15 - Insert Remaining Crossbar Rails

- A. Insert a Crossbar Rail (P12) into each of the two openings at the end of the Long Corner Crossbar End (P6) of the corner Leg assembly as shown.
- B. Slide the Crossbar Rails as far as they will go into the Long Corner Crossbar End.

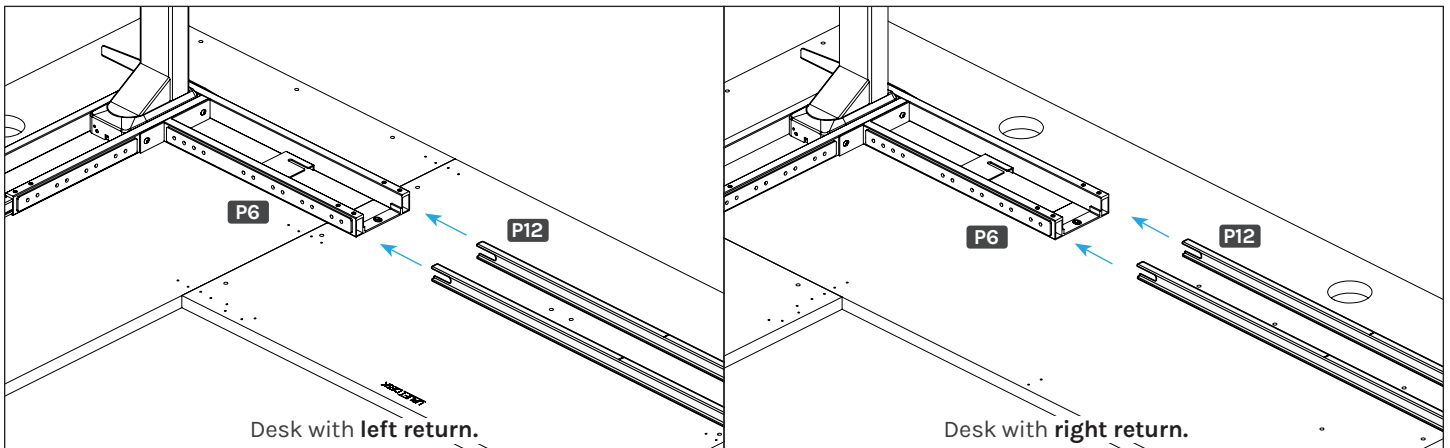

Step 16 - Place & Attach Remaining Leg Assembly

- A. Position the remaining Leg assembly as shown and slide the Crossbar End (P4) onto the ends of the Crossbar Rails (P12).

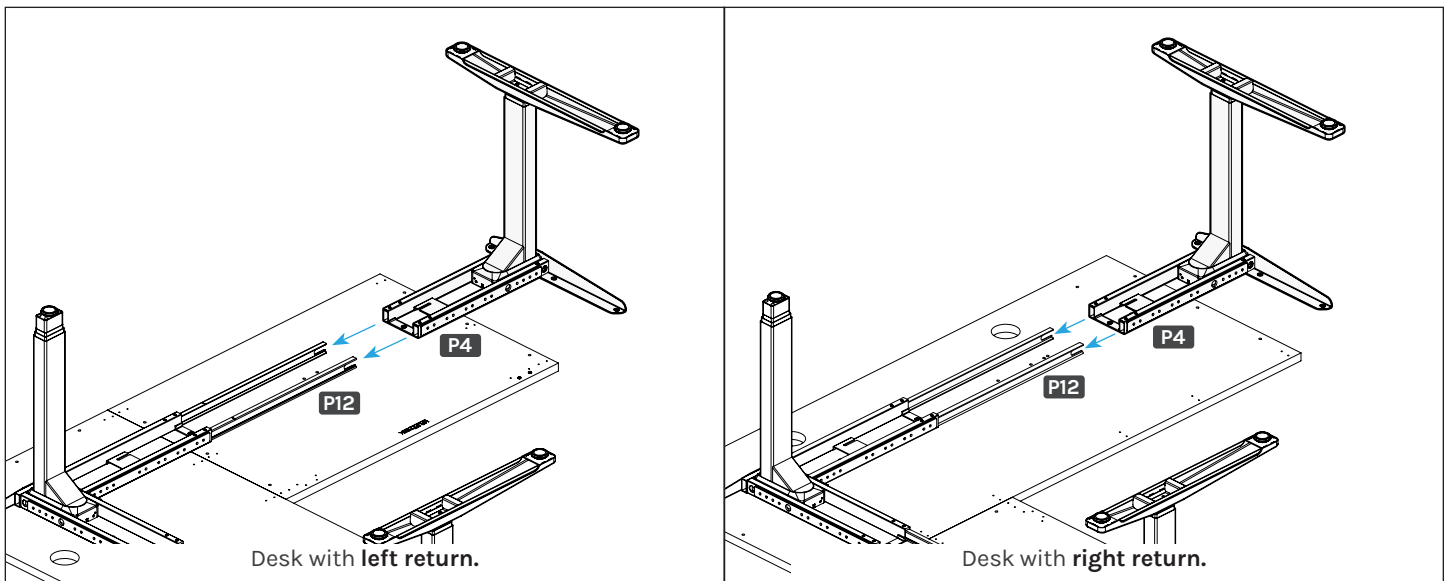

- B. Align the holes in the Side Bracket and Crossbar End with the pre-drilled holes or metal threaded inserts in the desktop.
 - C. Use a Phillips Screwdriver to insert a Screw (**H4a or H4b**) and Washer (**H5**) through each of the holes shown in the Side Bracket and Crossbar End and into the pre-drilled holes or metal threaded inserts in the desktop.
- Do not tighten the screws until all have been started. Be sure not to over tighten to avoid stripping.

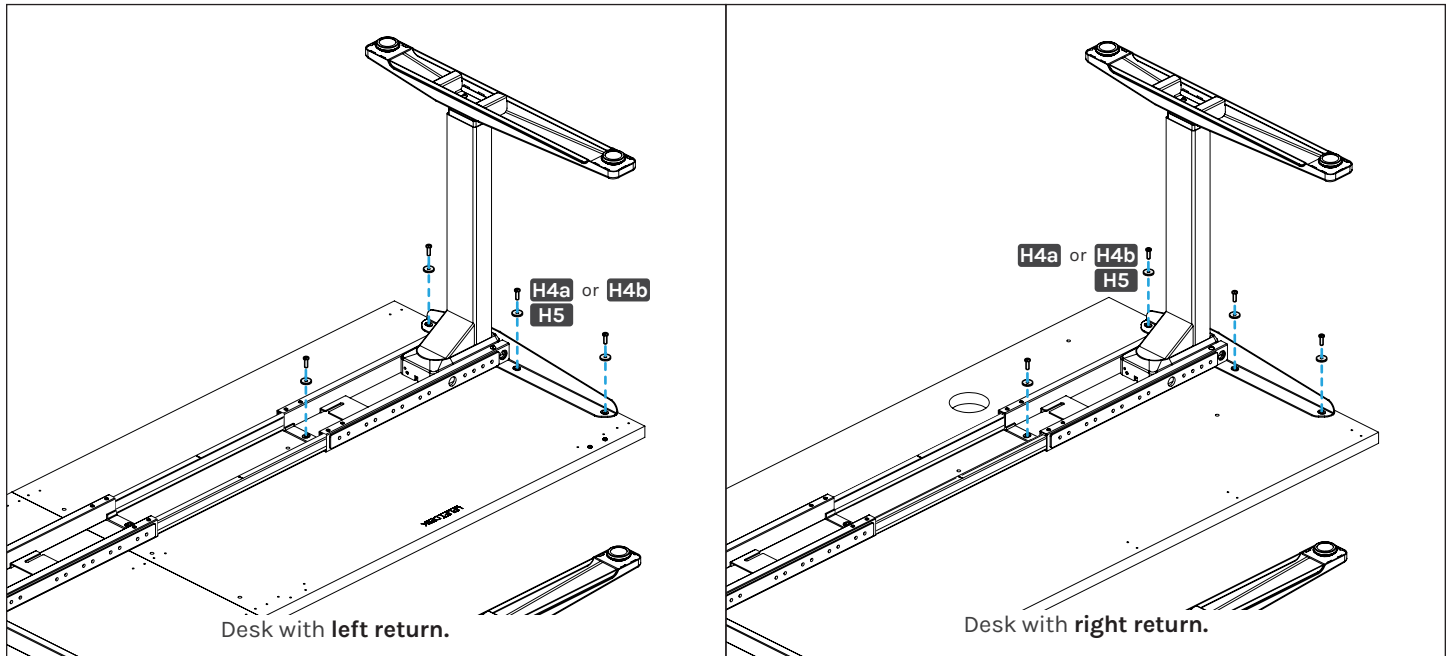

Step 17 - Attach Keypad

Keypad mounting holes are pre-drilled into UPLIFT return desktops. Locations for attaching the Keypad on left and right returns are shown below.

- A. Align the mounting slots of the Keypad (**P14**) with the pre-drilled holes in the desktop that line up with the holes in the Keypad.
- B. Use a Phillips Screwdriver to attach the Keypad to the desktop with two #10 x 5/8" Wood Screws (**H14**). Be careful not to overtighten the screws to avoid stripping.

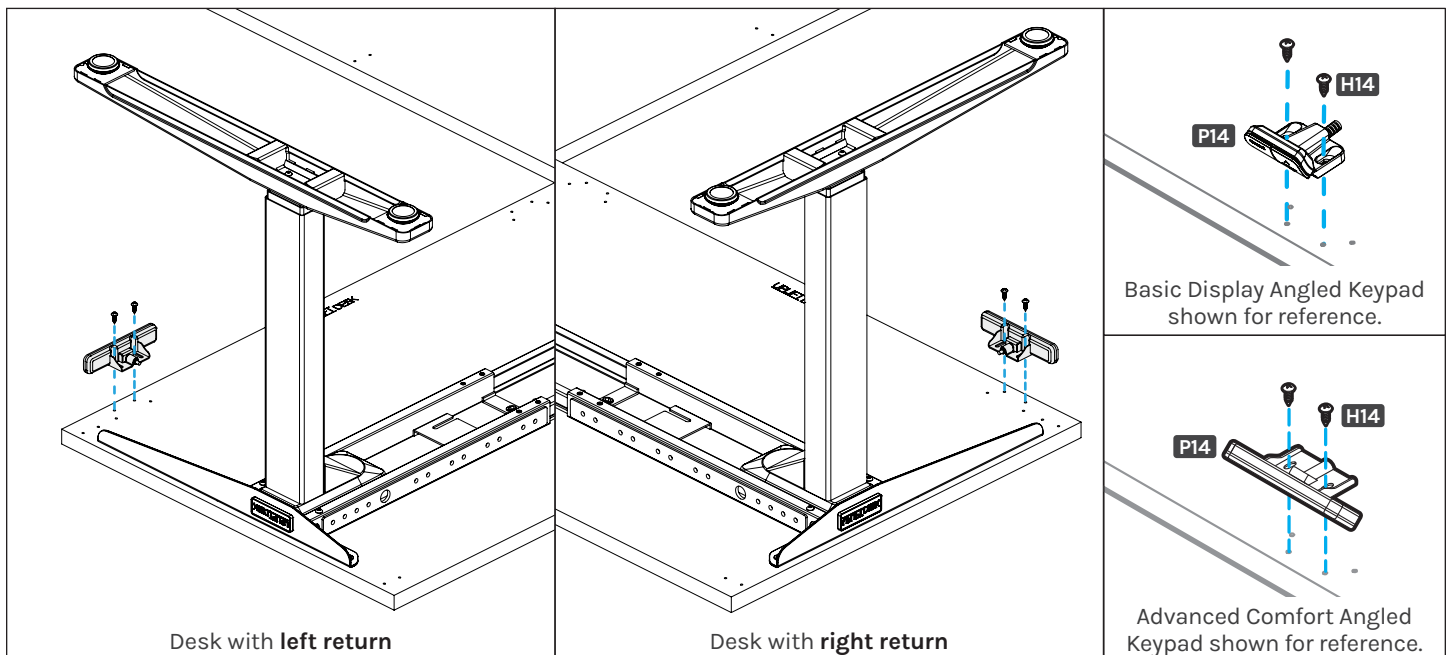

Step 18 - Attach Control Box

The Control Box (**P15**) must be attached to the desk frame for the desk to function properly. It should be attached to the Long Corner Crossbar End on the corner Leg assembly.

- Position the Control Box where shown with the port labeled "AC" facing away from the corner Leg.
- Slide the Control Box onto the Long Corner Crossbar End so that the mounting hooks on the bottom of the Control Box interlock with the slots in the Crossbar End capture plate.

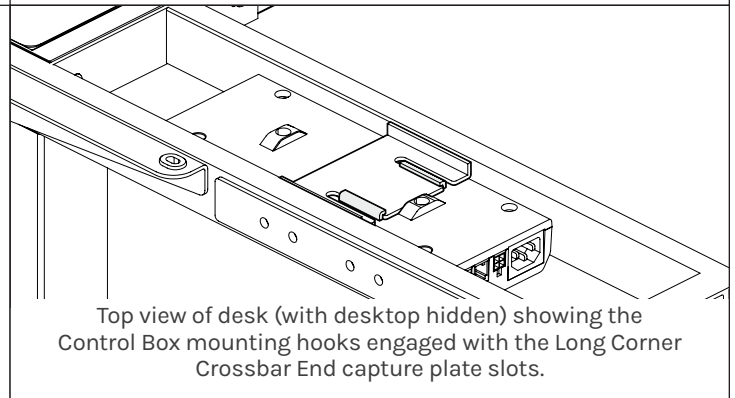
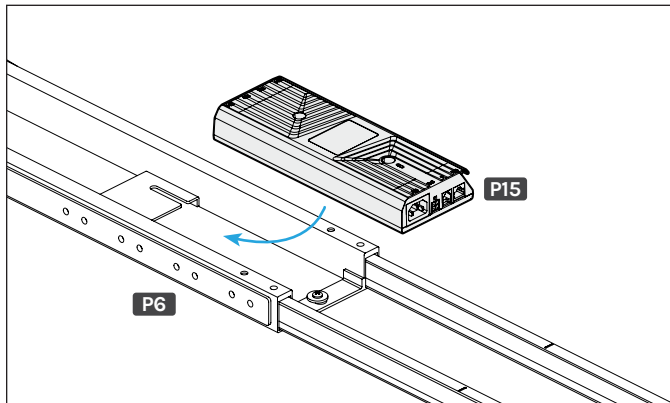
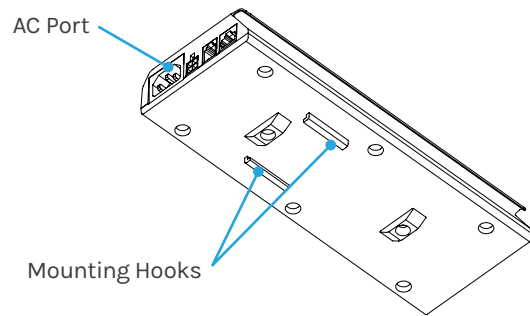

Step 19 - Install Casters (optional)

If you have casters for your desk, install them before flipping the desk sections over.

- Rotate the pre-installed Leveling Glides counterclockwise to remove them from the threaded holes in the Feet.
- Rotate the threaded stem of the Caster clockwise into the threaded holes in the Feet to install the Casters.
- If your Casters have a hex nut between the threaded stem and wheels, you can use a 1/2" (12mm) or adjustable wrench (not included) to assist with the Caster installation process.

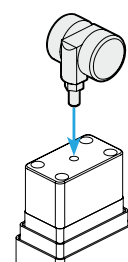
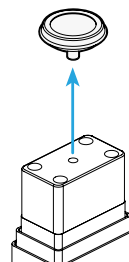
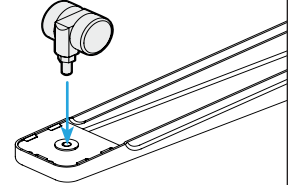
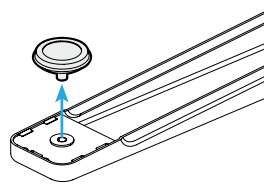

Step 20 - Separate Main & Return Desk Sections

The desk will be flipped upright for the remainder of the assembly. Flipping the return and main desk sections individually is much easier and safer than attempting to flip the complete L-shaped desk assembly. It can also prevent damage to the desk assembly. In preparation to flip the desk over, first separate the return desk section from the main desk section.

- Slide the Crossbar Rails that extend over the return desktop into the Corner Crossbar Ends as far as they will go.
- Slide the return desk section far enough away from the main desk section that each section can be individually flipped over.

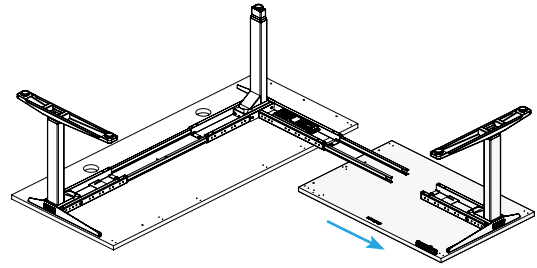

Desk with left return.

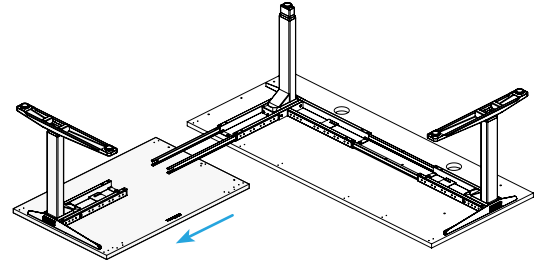

Desk with right return.

Step 21 - Flip Desk Sections Upright

When preparing to flip the main desk section over, be aware of the Crossbar Rails and flip toward the back side of the desktop, away from the Crossbar Rails.

- With one person located at each end of the desk, grasp a desk Leg with one hand and the desktop with the other and carefully lift while rotating the desk so the Crossbar Rails are facing up.
- Readjust your grip and continue to rotate the desk until it is right-side up.
- Rotate the desk to the position shown.

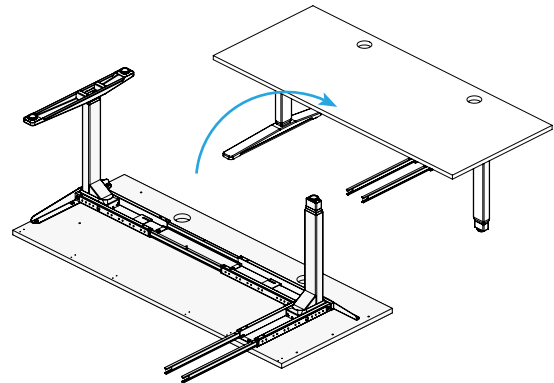

- Flip the return desk section over and position it against the main desk section, resting on the Crossbar rails as shown.

Note: If you are assembling a **Custom Solid Wood Desktop** that has slots in the edges as shown below, insert the two included football-shaped “biscuits” into the slots where the main and return desktops meet before pushing the two parts together.

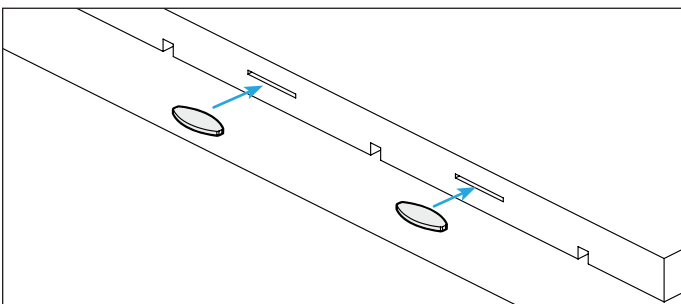

- From below the desk, slide the Crossbar Rails into the Crossbar End on the return desk section.

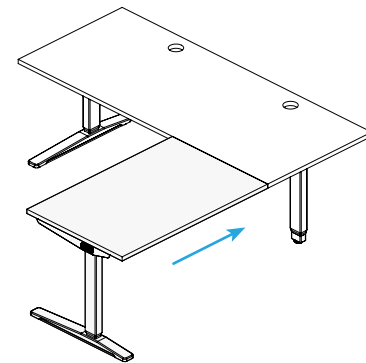

Desk with right return shown.

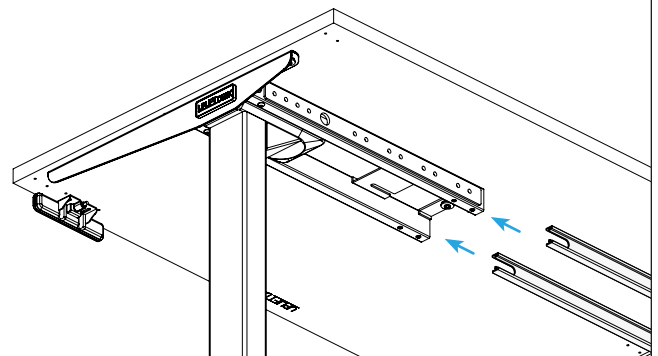

Step 22 - Attach Support Brackets

Before attaching the Support Brackets (H11), be sure that the main and return desktops are aligned with the edges flush to each other and there is no gap between the two desktops.

- Align each of the Support Brackets with the holes in the main and return desktops.
- Attach the Support Brackets to the main and return desktops with four #10 x 3/4" Wood Screws (H4a) per bracket as shown.

Note: For Custom Solid Wood Desktops, discard the Support Brackets and insert the three "Dogbone Bolts" into the pockets in the main and return desktops and tighten with an adjustable wrench.

For desks with left returns, insert the Screw selected in Step 14 (H4a or H4b) and a Washer (H5) where indicated on the return.

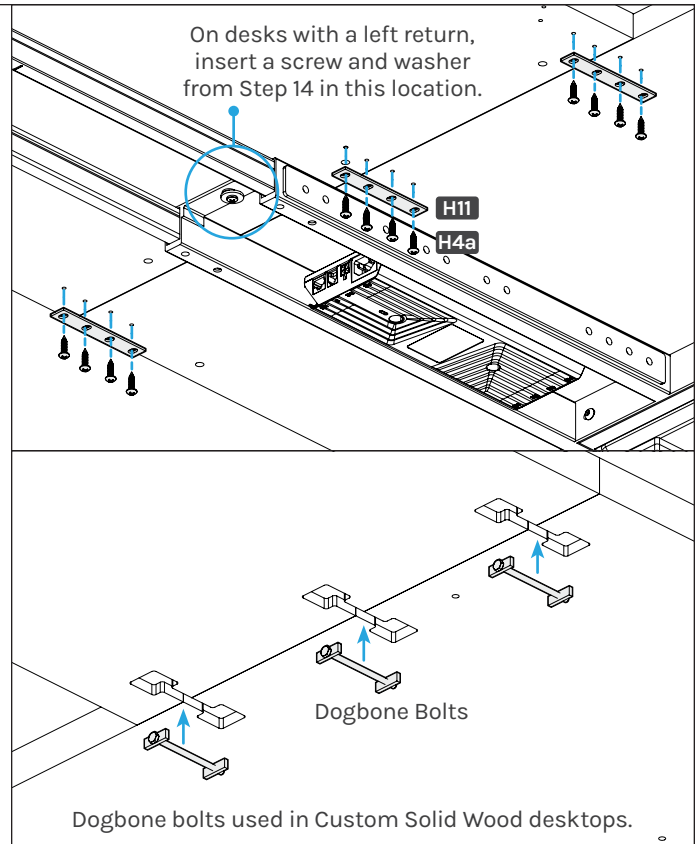

Step 23 - Secure Crossbar Rails

- Locate the center indicator mark on the narrow sides of each Center Rail.
- Slide each Crossbar Rail (P12) left or right until the center indicator marks are approximately centered between the Crossbar Ends.
- Insert four M8 x 8 Set Screws (H3) into each Crossbar End and tighten using the 4mm Allen Wrench (H6).

IMPORTANT: Ensure that all set screws are making contact with the Crossbar Rails inside the Crossbar Ends and are tight before proceeding.

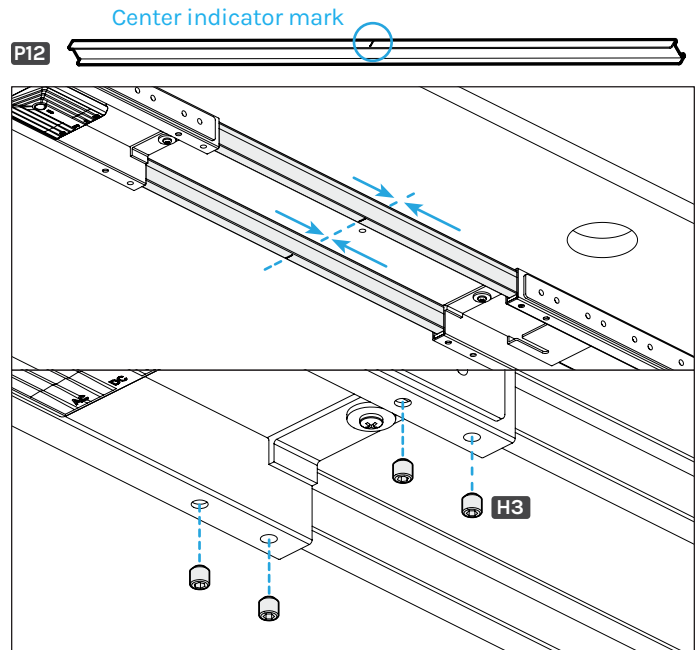

Step 24 - Connect Cables

- A. Ensure the Control Box is firmly in place and connect the Power Cable (**P16**) to the port on the Control Box labeled “AC”.
- B. Connect the long Leg Extension Cable (**P17**) to the cable of whichever Leg is furthest from the corner Leg, either on the main or return desktop.
- C. Connect a short Leg Extension Cable to each of the other two Leg cables.
- D. Plug each of the Leg Extension Cables into the ports in the Control Box marked “M1”, “M2”, and “M3”. It does not matter which cable is plugged into each port.
- E. The Leg Extension Cable coming from the Leg opposite the Control Box can be tucked under the cable channel along the side of the Control Box.
- F. Connect the Keypad cable into the Control Box port labeled “HS”.

The Control Box port labeled “F” is used to connect the Bluetooth Adapter (FRM125) for use with the UPLIFT Desk App.

The Control Box port labeled “DC” is used to power low voltage accessories with compatible connectors.

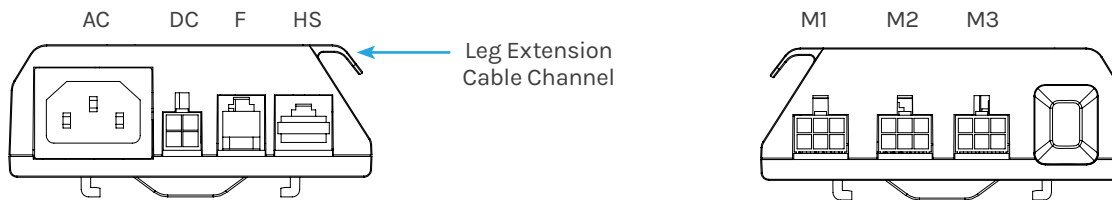

Attach Cable Mounts (optional)

Ten Cable Mounts (**H9**) are provided with your desk to attach under the desktop and organize cables. Organizing cables improves the appearance of your desk and prevents cables from snagging on anything while the desk is moving up and down.

IMPORTANT: The adhesive backing on the Cable Mounts is very strong, so carefully consider where you would like to locate them before attaching to the bottom of the desktop or desk frame.

- Peel the backing off the back of the plastic mount to expose the adhesive pad.
- Position the mount where you would like to attach it and press firmly for 10 seconds.
- Take one of the hook and loop strips and slide it through the openings in the plastic mount.
- Bundle cables and wrap the hook and loop strip around the bundle to secure it in place.

Hook and loop strips can also be used without the plastic mounts in places where they can be slid through the gap between the underside of the desktop and the frame.

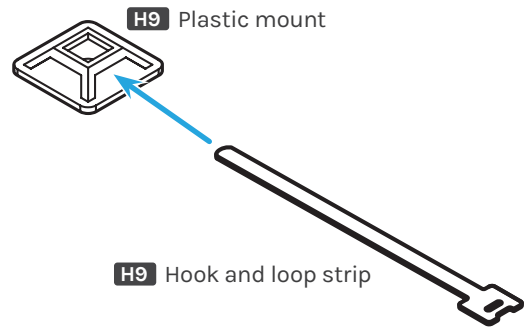

Attach Wire Management Tray (optional)

The included Wire Management Tray (**P16**) can be located wherever you feel it will be most convenient to use. If your desktop includes grommet holes, the Wire Management Tray works nicely located between them.

- Position the Wire Management Tray where you would like it to be attached. The tray can be installed with the opening facing the front of the desktop (as shown) or the back of the desktop, whichever is most convenient for you to access.
- Use a Phillips Screwdriver to attach the Tray to your desktop using two #10 x 5/8" Wood Screws (**H14**).

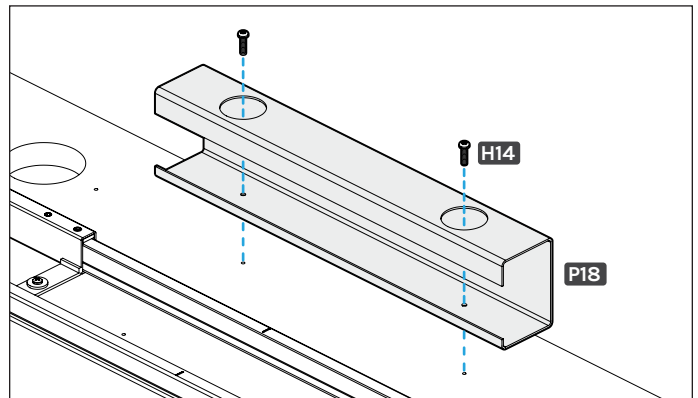

Install Accessory Anchor Plates (optional)

Some UPLIFT Desk accessories are designed to attach to the patented mounting points located on front and back of the Crossbar Ends. Some of these accessories require the use of the included Anchor Plates (**P11**). Refer to the instructions provided with each accessory for specific mounting instructions.

- Align the two smaller holes in one of the Anchor Plates with two of the threaded holes in the Crossbar End.
- Loosely insert two of the M8 x 10 Screws (**H7**) through Anchor Plate holes and into the threaded holes in the Crossbar End.
- Tighten the screws using the 5mm Allen Wrench (**H8**) and Allen Wrench Handle (**H15**).

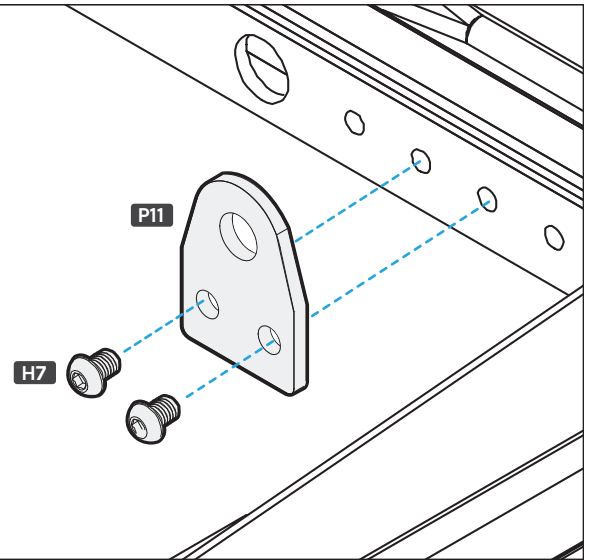

Insert Grommet Covers (optional)

Follow the steps below for installing Grommet Covers, if a different grommet option was selected, follow the instructions included with your grommet option.

- Place the Grommet Covers over the grommet holes and press down until the edges of the Grommet Covers are flush with the desktop surface.
- Remove the Grommet Cover lid or rotate the aperture cover to pass cables through the Grommet Cover housing.
- Replace the lid.

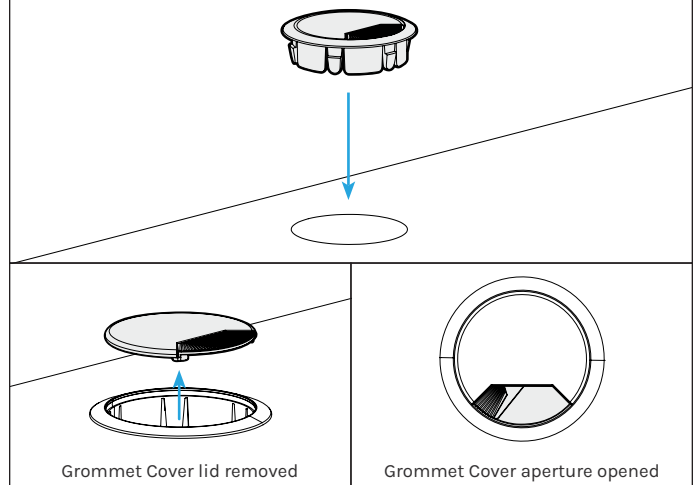

Position Desk

Position the desk where you would like it to be. Don't lift the desk by just the desktop, doing so may put undue stress on the attachment screws and threaded inserts. Hold the frame Side Brackets when lifting.

- If your desk has Casters, moving is easy. If the Casters include locks, unlock them and roll the desk to the desired location. Once in place, relock the Casters to keep the desk stationary and improve stability.
- If your desk does not have Casters, it's recommended to use three people to lift the desk on each end and at the corner—do not drag it. Be sure to lift by placing your hands under the frame Side Brackets where indicated by the arrows instead of lifting by the desktop.

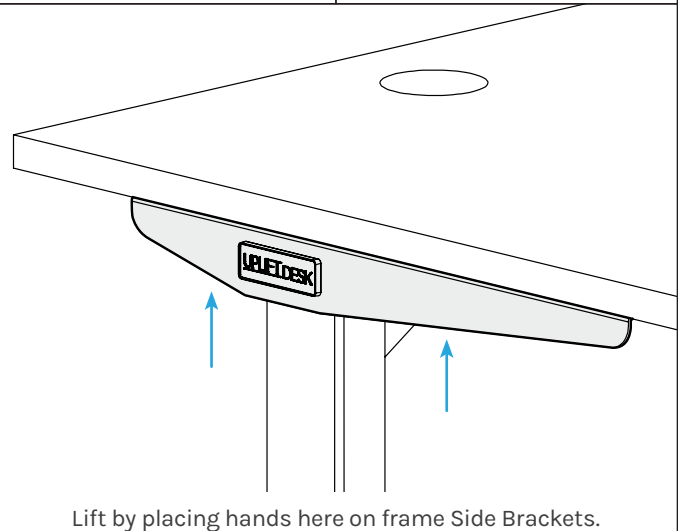

Prepare Desk & Surroundings

- A. Check the desk's surroundings to make sure there will be no obstacles within the desk's path while it is being raised or lowered. Do not place any objects underneath the desk that are taller than 21" and be aware of any accessories mounted above or below your desk.
- B. Adjust the Leveling Glides as needed to level the desk. Each Leveling Glide provides up to $\frac{3}{8}$ " of leveling.
- C. Ensure that the Power Cord and all accessory cords are long enough to accommodate the raising and lowering of your desk.
- D. Plug your desk into a grounded, 100-240V power outlet. If you have a Keypad with a display you should see it light up confirming the desk is powered. If you have a Keypad without a display, look at the Control Box under the desk to see if the small LED indicator is illuminated.
- E. Perform the desk reset procedure below. Slowly lower and raise the desk while watching all cables and clearances to ensure there are no cable snags or obstacles.

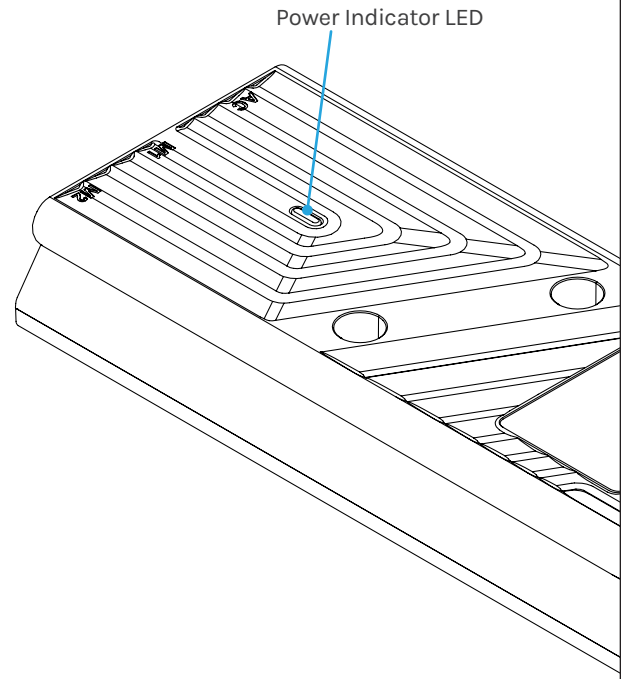

Perform Desk Reset Procedure

IMPORTANT: Before using your desk, perform the Desk Reset Procedure below to sync the Legs and Control Box.

1. Remove all items from under the desk to allow it to travel to its lowest height.
2. Press the down button once.
3. Hold the down button until the desk stops at its lowest position.
4. Hold the down button again for 30 seconds or until the display changes. Keypads with a display will show "ASr" when ready to reset. Paddle Keypads will display "RESET."
5. Hold the down button again until the desk lowers slightly, rises, and stops. If the desk didn't move, try this step again.
6. Try operating the desk. If the desk is working properly, you're done. If the desk is not working properly, continue with the following steps.
7. Unplug the power cord from the electrical outlet.
8. Hold the down button for 10 seconds to discharge any stored power in the control box.
9. Plug the desk back in and restart the Desk Reset process steps a second time.
10. Try operating the desk again. If the desk is working properly, you're done and the desk is ready to use.

If you have an Advanced Keypad, see the Programming section below for further information on how to use your Keypad.

These UPLIFT Desk programming instructions are compatible with all UPLIFT Advanced Keypads except the Advanced Paddle Keypad.

For Advanced Paddle Keypad programming steps, refer to the instructions provided with that Keypad.

Set & Use Memorized Heights

Save heights on the keypad:

1. Hold the up or down button to move the desk to the desired height.
2. Tap the “M” button followed by a number button (1, 2, 3, or 4) to assign the current height to that number.
3. Once the memory buttons are programmed, tap a numbered button and the desk will automatically move to the preset height.

If you would rather the button be pressed and held instead of tapped to make height adjustments, see One-Touch or Constant-Touch below.

One-Touch, Constant-Touch, or Double-Tap

One-touch is the default setting of the control box and requires only a single touch of a keypad button to move the desktop to a saved height. Constant-touch requires the continuous hold of a button or paddle to move the desktop to a saved height. Double-tap requires pressing the keypad button twice to move the desktop to a saved height. This helps avoid accidental activation of the desk if a keypad button is bumped.

Toggle between one-touch and constant-touch modes:

1. Hold the down button until the desk reaches its lowest position.
2. Hold the down button again until the display flashes “ASr.”
3. Hold the “1” button until the display shows “10.1” (one-touch), “10.2” (constant-touch), or “10.8” (double-tap), and then goes back to “ASr.” While the display is flashing “ASr,” hold the “1” button to toggle between the three settings.
4. Wait for the display to change back to “ASr.”
5. Hold the “down” button until the desktop lowers and rises slightly and the display changes back to the numeric height setting.

Keypad Lock

Lock the keypad to prevent accidental adjustments:

1. Hold the “M” button until the display shows “LOC.”
2. To unlock your keypad, hold the “M” button until the display shows the current numeric height setting.

In the event of a power outage, the keypad will return to the unlocked setting.

Units of Measurement

Switch between inches and centimeters on your display:

1. Hold the down button until the desk reaches its lowest position.
2. Hold the down button again until the display flashes “ASr.”
3. Hold the “2” button until the display shows “10.3” (centimeters) or “10.4” (inches) and then goes back to “ASr.” While the display is flashing “ASr,” hold the “2” button to toggle between the two settings.
4. Wait for the display to change back to “ASr.”
5. Hold the “down” button until the desktop lowers and rises slightly and the display changes back to the numeric height setting.

Calibrate Desk Height

Compare the desk height to the displayed height:

1. Press and hold the “down” button until the desk reaches its lowest position.
2. Use a tape measure to check the height from the floor to the top surface of the desktop. If the measurement matches the displayed height, the desk is already calibrated and ready for use.

If the displayed height doesn't match the desk's actual height, follow these steps:

1. Hold the down button until the display flashes “ASr.”
2. Hold the “M” button until the numeric display begins flashing.
3. Tap the up or down button to adjust the displayed height to match your desk's measured height.
4. Wait for the display to change back to “ASr.”
5. Hold the “down” button until the desktop lowers and rises slightly and the display changes back to the numeric height setting.

Max/Min Height Limits

Set the desk's maximum height limits:

1. Hold the up or down button to move the desk to the desired height.
2. Tap the “M” button once and “S-” will appear on the display.
3. Tap the up button and the display will flash “S-.”
4. Hold the “M” button until the display shows “999” and changes to the numeric height of the now set upper limit.

Set the desk's minimum height limits:

1. Hold the up or down button to move the desk to the desired height.
2. Tap the “M” button once and “S-” will appear on the display.
3. Tap the down button and the display will flash “S-.”
4. Hold the “M” button until the display shows “000” and changes to the numeric value of the now set lower limit.

Remove the maximum and minimum height limits:

1. Tap the “M” button once and the display will show “S-.”
2. Hold the “M” button until the display shows “555” and changes to the current numeric height setting.

Anti-Collision System Sensitivity Adjustment

Adjust the sensitivity on your desk's advanced anti-collision system:

1. Hold the down button until the desk reaches the lowest position.
2. Hold the down button again until the display flashes “ASr.”
3. Hold the UP button until the display shows “10.5,” “10.6,” or “10.7”. This is your current anti-collision sensitivity setting.
10.5 = most sensitive setting (possible false positives)
10.6 = moderate sensitivity setting
10.7 = least sensitive setting

While “ASr” is flashing, press the up button to toggle between the three settings.

4. Wait for the display to change back to “ASr.”
 5. Hold the “down” button until the desktop lowers and rises slightly and the display changes back to the numeric height setting.
-

Error Code	Description	Troubleshooting Solution
H01	Overheated	The desk motor has a 10% duty cycle to protect from overheating. For example, in a 20 minute period if your desk motor is activated for 2 minutes you will want to let it rest for 18 minutes. Otherwise you may see an H01 code on your keypad
E01-E06	Firmware or connectivity issues	Check all cables to ensure they're all firmly plugged in, and perform Reset Procedure above
E07-E012	Legs are uneven	Perform Reset procedure

Starting & Stopping

If your desk is continuously starting and stopping as you try to raise or lower it, check to make sure the Control Box is securely attached to the frame. The Control Box **MUST** be attached to your frame in order for your desk to function properly.

Desk Reset Procedure

If your keypad display shows any of the error codes listed, perform the Desk Reset Procedure provided at the end of the desk assembly steps to clear it. If the error message persists after performing the reset procedure or if there is a height difference between the Legs of more than 1.5", email us at support@upliftdesk.com or call 800-349-3839.

Perform the desk reset procedure any time the desk is unplugged or loses power.

UPLIFT DESK®

Work Better. Live Healthier

upliftdesk.com

info@upliftdesk.com

800-349-3839

512-614-3152

SAVE THIS MANUAL

Study this manual carefully. If this product is sold, please provide this manual to the buyer, installers, or support personnel operating the product.



Copyright Notice: This manual is a component of this UPLIFT Desk product. This manual is a part of the scope of delivery, even if the item is resold. This manual is also available on the UPLIFT Desk website: upliftdesk.com. This manual is subject to United States copyright law.