

V2 L-Shaped Standing Desk Frame

F550-F551

Specifications

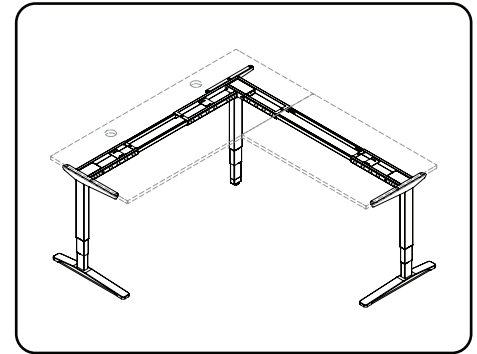

Pictured: frame and desktop placement

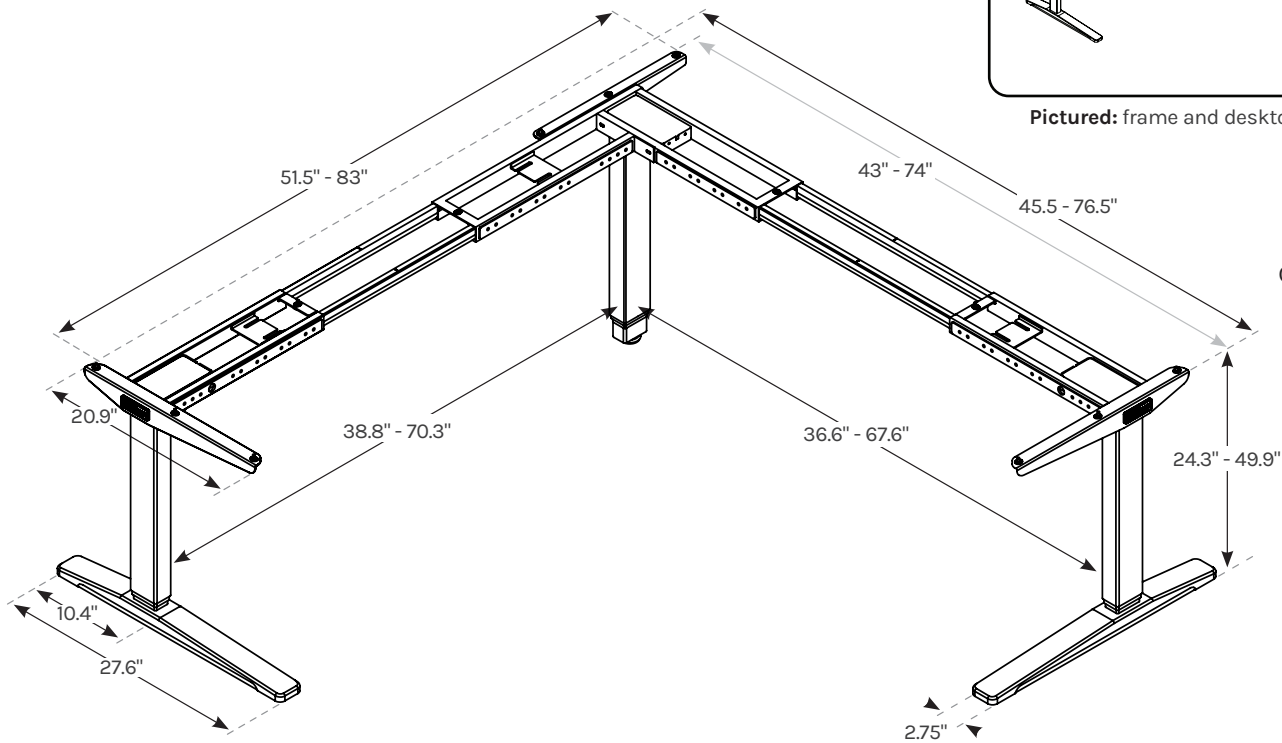

Contract-grade Quality

Warranty	15 year warranty on all UPLIFT Desk products. upliftdesk.com/warranty/	Award winning desk frame	Superior anti-collision sensitivity
Height range	24.3"-49.9"	Patented frame mounting points	Improved stability with 33% larger, precision tolerance legs
Travel speed	2" per second	15 year warranty	Free wire management included
Noise level	<48 dB	Dual motor design with 535 lb lifting capacity	Energy efficient & whisper quiet
Lifting capacity	535 lbs	33% faster & 33% greater height range than 2-stage legs	Meets ANSI/BIFMA X5.5-2021 Desk & Table Products standard for safety, durability, and structural performance
Input voltage	100-240V	Stability brace on each Leg	
Output power	450W		
Standby power consumption	0.1W		
UL listing	US & Canada		

Copyright Notice: This guide is a component of this UPLIFT Desk product. This guide is a part of the scope of delivery, even if the item is resold. This guide is also available on the UPLIFT Desk website: [upliftdesk.com](https://www.upliftdesk.com). These specifications are subject to United States copyright law.