

Height Adjustable Conference Table Frame

F580-F581 Ping-Pong Conference

Specifications

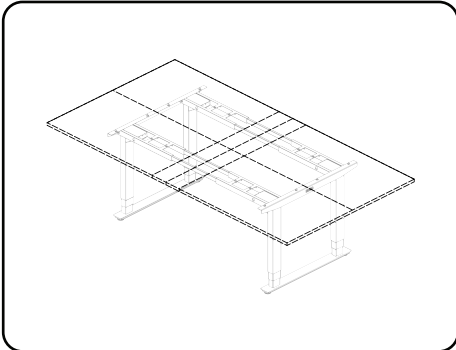

Pictured: frame and conference ping-pong tabletop

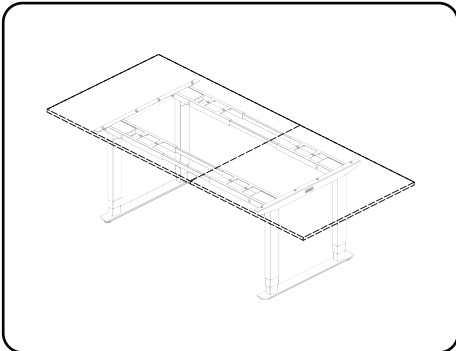

Pictured: frame and conference tabletop

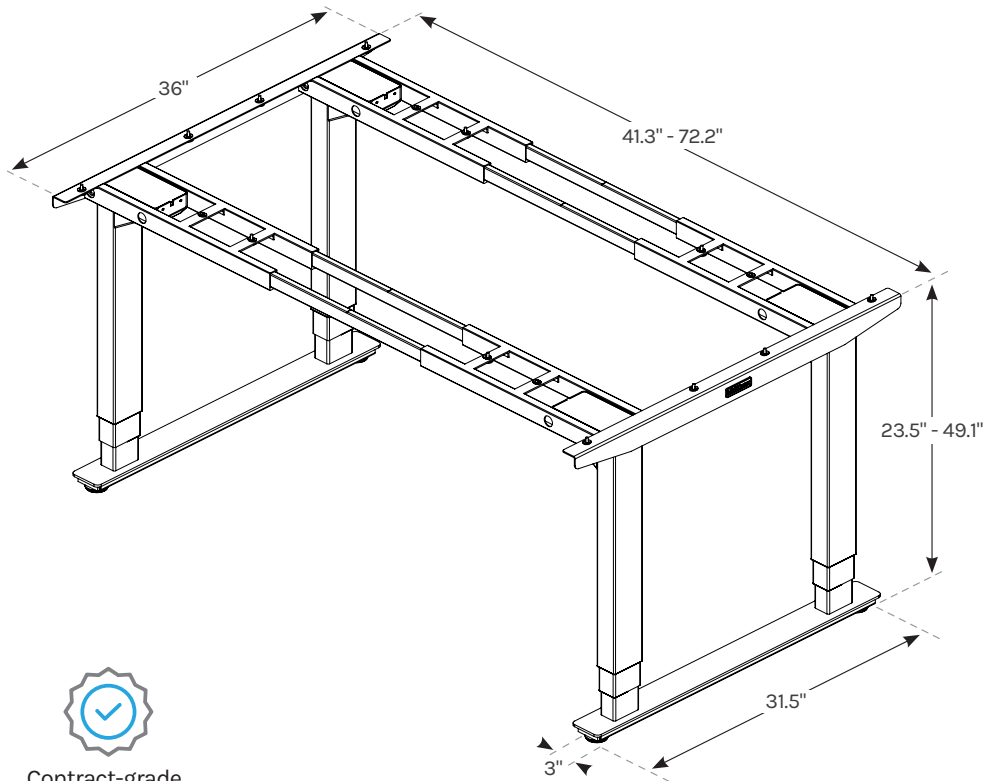

Contract-grade Quality

| | | | |
|---------------------------|-----------------------------------------------------------------------------------------------------------------------|---------------------------------------------------------|--------------------------------------------------------------------------------------------------------------|
| Warranty | 15 year warranty on all UPLIFT Desk products. upliftdesk.com/warranty/ | Award winning desk frame | Superior anti-collision sensitivity |
| Height range | 23.5"-49.1" | 15 year warranty | Improved stability with 33% larger, precision tolerance legs |
| Travel speed | 2" per second | Dual motor design with 535 lb lifting capacity | Free wire management included |
| Noise level | <48 dB | 33% faster & 33% greater height range than 2-stage legs | Energy efficient & whisper quiet |
| Lifting capacity | 535 lbs | Stability brace on each Leg | Meets ANSI/BIFMA X5.5-2021 Desk & Table Products standard for safety, durability, and structural performance |
| Input voltage | 100-240V | | |
| Output power | 450W | | |
| Standby power consumption | 0.1W | | |
| UL listing | US & Canada | | |

Copyright Notice: This guide is a component of this UPLIFT Desk product. This guide is a part of the scope of delivery, even if the item is resold. This guide is also available on the UPLIFT Desk website: upliftdesk.com. These specifications are subject to United States copyright law.