

UPLIFT V2-Commercial Standing Desk

F600 (C-Frame)

Specifications

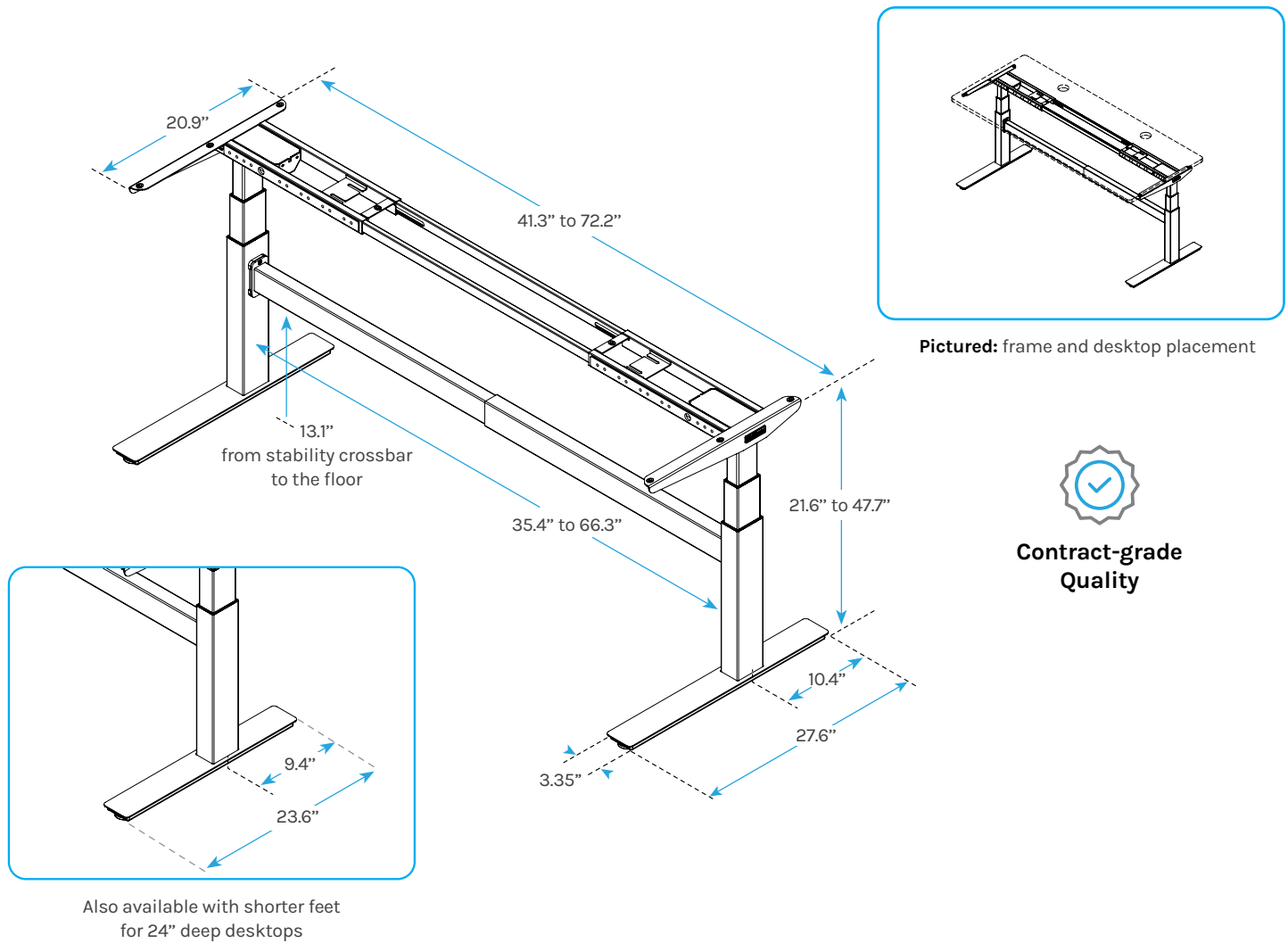

| | |
|---------------------------|---|
| Warranty | 15 year warranty on all UPLIFT Desk products. upliftdesk.com/warranty/ |
| Height Range | 21.6"-47.7" |
| Travel Speed | 2" per second |
| Noise Level | <48 dB |
| Lifting Capacity | 355 lbs |
| Input Voltage | 100-240V |
| Output Power | 400W |
| Standby Power Consumption | 0.1W |
| UL Listing | US & Canada |

- Award winning desk frame
- Patented frame mounting points
- 15 year warranty
- Dual Motor Design with 355 lb lifting capacity
- 33% faster & 33% greater height range than 2-stage legs
- Stability crossbar
- Superior anti-collision sensitivity
- Improved stability with 33% larger, precision tolerance legs
- Free wire management included
- 41.3" - 72.2" width adjustment
- Energy efficient & whisper quiet
- Meets BIFMA G1-2013 Height Standard
- Meets BIFMA X5.5-2021 Durability Standard

Copyright Notice: This guide is a component of this UPLIFT Desk product. This guide is a part of the scope of delivery, even if the item is resold. This guide is also available on the UPLIFT Desk website: upliftdesk.com. These specifications are subject to United States copyright law.