

UPLIFT V2-Commercial Standing Desk

F600 (C-Frame)

Specifications

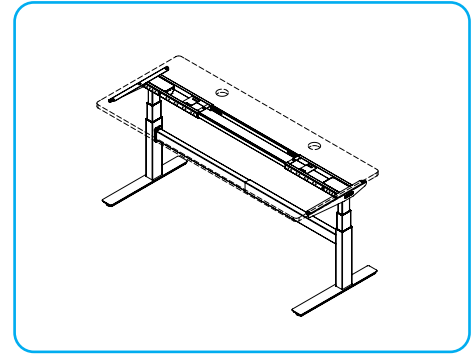
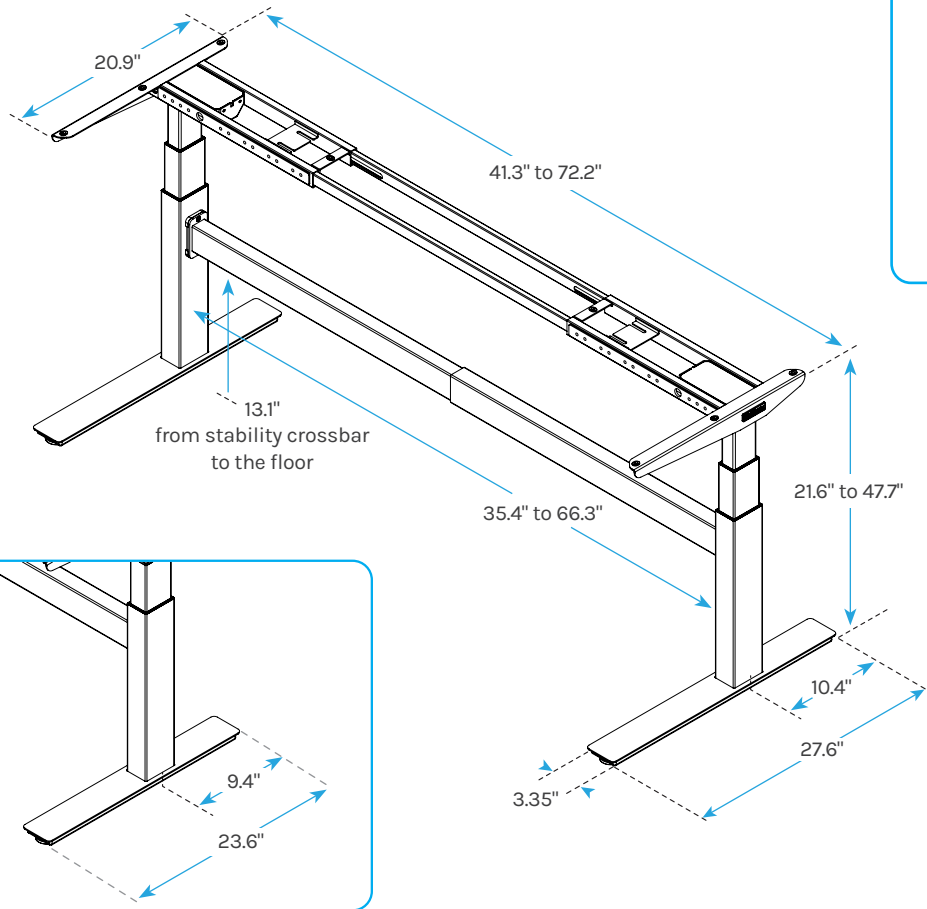

Pictured: frame and desktop placement



**Contract-grade
Quality**

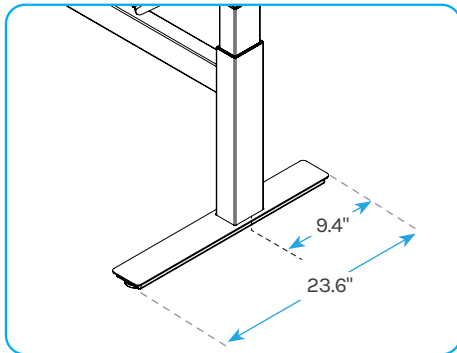

Also available with shorter feet
for 24" deep desktops

Warranty	15 year warranty on all UPLIFT Desk products. upliftdesk.com/warranty/
Height Range	21.6"-47.7"
Travel Speed	2" per second
Noise Level	<48 dB
Lifting Capacity	355 lbs
Input Voltage	100-240V
Output Power	400W
Standby Power Consumption	0.1W
UL Listing	US & Canada



Award winning desk frame



Patented frame mounting points



15 year warranty



Dual motor design with 355 lb lifting capacity



33% faster & 33% greater height range than 2-stage legs



Stability crossbar



Superior anti-collision sensitivity



Improved stability with 33% larger, precision tolerance legs



Free wire management included



41.3" - 72.2" width adjustment



Energy efficient & whisper quiet

Meets ANSI/BIFMA X5.5-2021 Desk & Table Products standard for safety, durability, and structural performance and G1-2013 Ergonomic Guidelines for height.

ANSI/BIFMA

Copyright Notice: This guide is a component of this UPLIFT Desk product. This guide is a part of the scope of delivery, even if the item is resold. This guide is also available on the UPLIFT Desk website: [upliftdesk.com](https://www.upliftdesk.com). These specifications are subject to United States copyright law.