

# UPLIFT V2-Commercial Standing Desk

F600 (T-Frame)

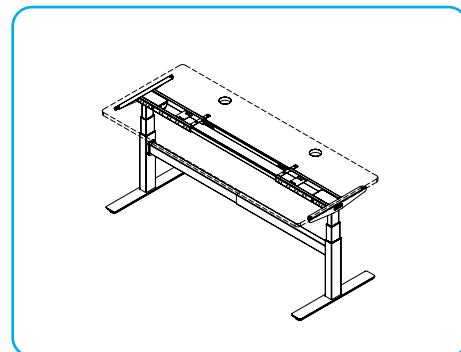

Pictured: frame and desktop placement

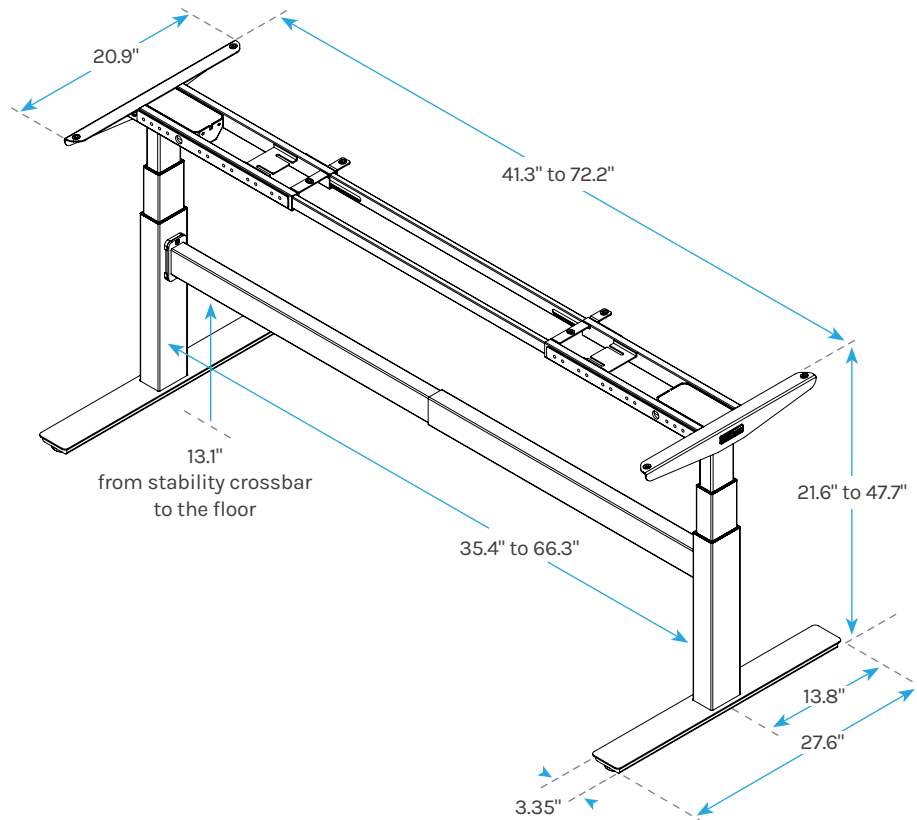

**Contract-grade Quality**

Warranty	15 year warranty on all UPLIFT Desk products. <a href="https://upliftdesk.com/warranty/">upliftdesk.com/warranty/</a>	Award winning desk frame	Improved stability with 33% larger, precision tolerance legs
Height Range	21.6"-47.7"	Patented frame mounting points	Free wire management included
Travel Speed	2" per second	15 year warranty	41.3" - 72.2" width adjustment
Noise Level	<48 dB	Dual Motor Design with 355 lb lifting capacity	Energy efficient & whisper quiet
Lifting Capacity	355 lbs	33% faster & 33% greater height range than 2-stage legs	<p>Meets ANSI/BIFMA X5.5-2021 Desk &amp; Table Products standard for safety, durability, and structural performance and G1-2013 Ergonomic Guidelines for height.</p> <p>ANSI/ BIFMA</p>
Input Voltage	100-240V	Stability crossbar	
Output Power	400W	Superior anti-collision sensitivity	
Standby Power Consumption	0.1W		
UL Listing	US & Canada		

Copyright Notice: This guide is a component of this UPLIFT Desk product. This guide is a part of the scope of delivery, even if the item is resold. This guide is also available on the UPLIFT Desk website: [upliftdesk.com](https://upliftdesk.com). These specifications are subject to United States copyright law.