

Flip Top Table

FRM067

UPLIFT DESK

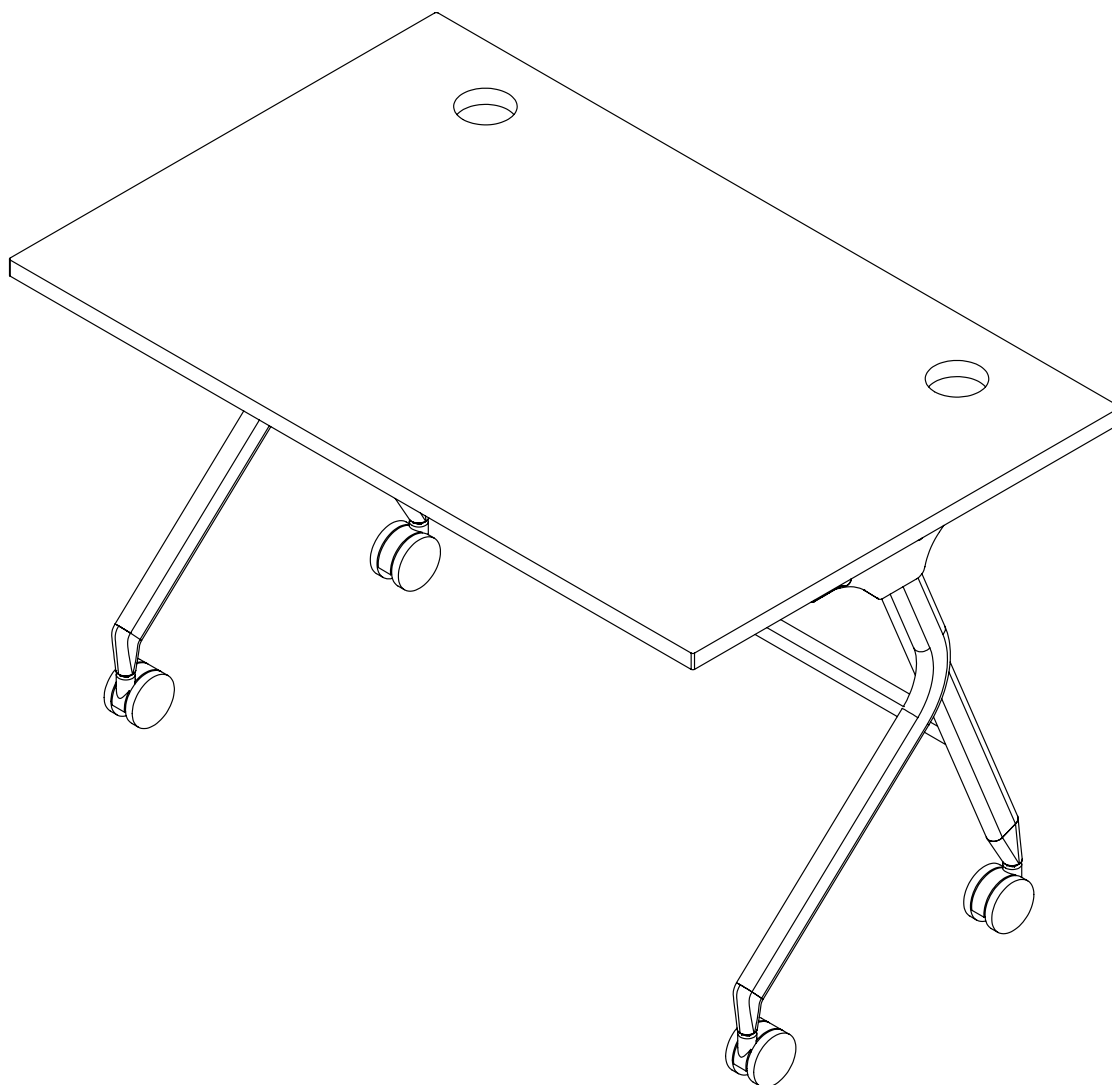

For assembly assistance,
visit upliftdesk.com/contact,
or call 800-349-3839,
or email info@upliftdesk.com

©2022 UPLIFT Desk®. All Rights Reserved

two person
assembly



Safety and Warnings



CAUTION: Read all instructions before assembly. Failure to assemble or operate properly may result in damage or personal injury. Retain manual for future reference.



WARNING: Keep children away from operating the tabletop surface flip unless supervised by an adult. Misuse of the table can cause personal injury.



WARNING: To avoid a pinch/crush injury, keep fingers and body parts clear of the Leg Assemblies while flipping the top surface up or down. Check the table's surroundings on all sides before flipping the top up or down to ensure there are no obstacles that can cause damage. Flipping the tabletop up or down can pinch or crush body parts trapped between the tabletop and stationary objects.



WARNING: Inspect the table regularly and stop using immediately if you notice any damaged or loose parts. Only replace damaged parts with authorized UPLIFT Desk parts and instructions.





WARNING: The table is designed for use in dry environments, indoors only.







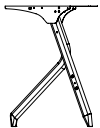
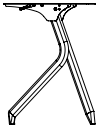
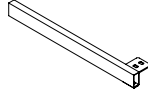
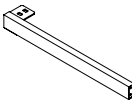
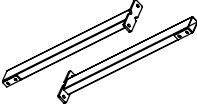
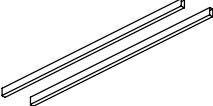
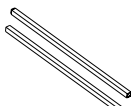

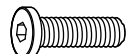

WARNING: Two people are recommended for assembly when lifting.

Under no circumstances does the manufacturer accept warranty or liability claims for damages caused from improper use of this table. Please provide these instructions to any new user or owner of the table.

Package Contents

P1 L Left Leg Assembly 	P1 R Right Leg Assembly 	P2 L Left Upper Crossbar End 	P2 R Right Upper Crossbar End 	P3 Lower Crossbar End qty 2 
P4 Crossbar Rail qty 2 	P5 Latch Release Crossbar End qty 2 	P6 Latch Release Crossbar Rail 	P7 Casters qty 4 	

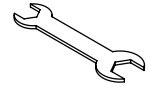
Hardware

H1 M6 x 10 Set Screw qty 14 	H2 M8 x 20 Machine Screw qty 4 	H3 M6 x 16 Machine Screw qty 4 	H4 #10-24 X 3/4" Machine Screw qty 8 	H5 #10 Flat Washer qty 8 
H6 5mm Allen Wrench 	H7 3mm Allen Wrench 	H8 Flat Wrench 17mm + 14mm 	H9 Rubber Bumper qty 2 	

Tools required (not provided)

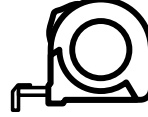
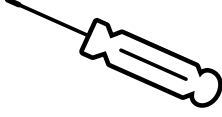
Tape Measure 	Phillips Head Screwdriver 
---	---

Component Diagram

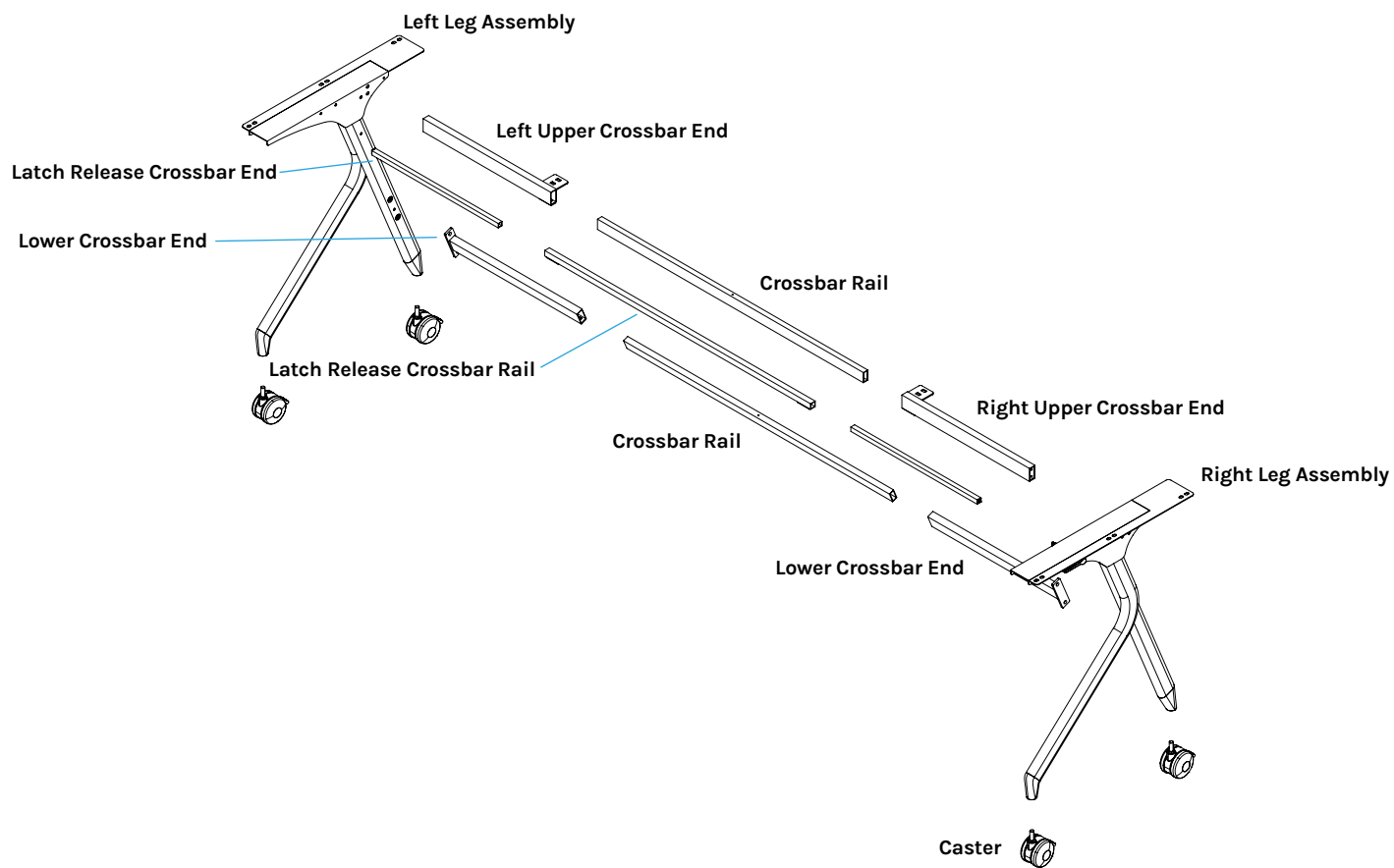

Step 1 - Inventory of Parts

- A. Two people are recommended for assembly.
- B. To avoid damage to your floor or Flip Top Table, we recommend assembling your table on a clean carpet, rug, or blanket.
- C. Ensure you have received all components and hardware before disposing of any packing material. Lay out the components from all boxes and make sure the items and quantities match what is shown in each of the package contents sections in these instructions.

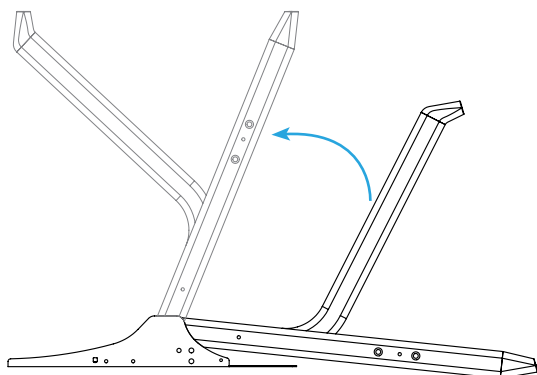

Step 2 - Upper Crossbar End Attachment

Upper Crossbar Ends and Leg Assemblies are marked with “L” and “R” labels to mark the left and right sides.

- A. Starting with the Right Leg Assembly (P1R), rotate the legs so they lock into place, perpendicular to the flat mounting plate as shown, then turn the assembly so the ends of the legs are facing up as shown.

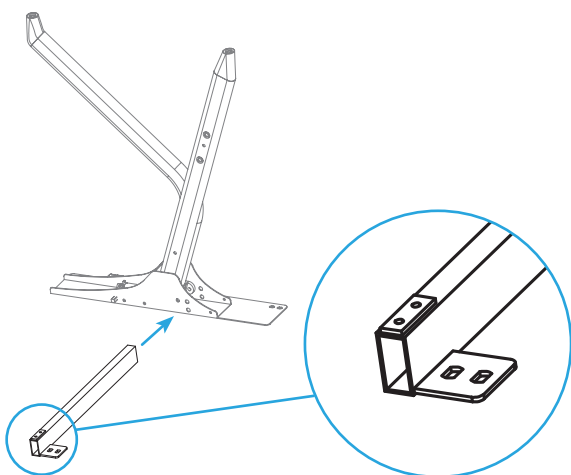

- B. Align the Right Upper Crossbar End (P2R) with the Right Leg Assembly as shown, with the circled holes facing up. The tab on the Upper Crossbar End will be facing toward the straight leg of the Leg Assembly as shown.

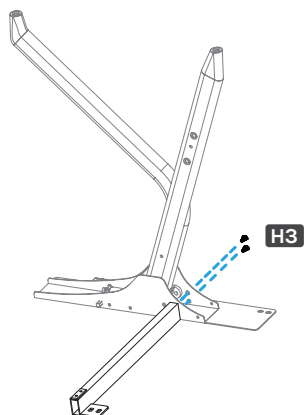

- C. Loosely insert two M6 x 16 Machine Screws (H3) through the Leg Assembly plate and into the end of the Upper Crossbar End, but do not tighten them yet.
- D. Using the long end of the 5mm Allen Wrench (H6) through the access holes in the Leg Assembly mounting plate, tighten the screws.
- E. Repeat this step for the Left Leg Assembly (P1L) and Left Upper Crossbar End (P2L).

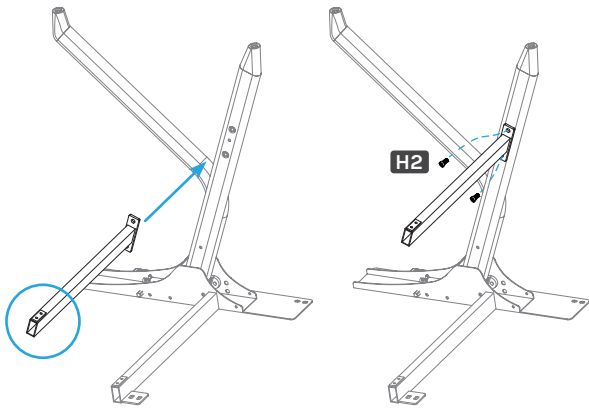

Step 3 - Lower Crossbar End Attachment

- Starting with the Right Leg Assembly (P1R), align one of the Lower Crossbar Ends (P3) with the circled end in the image facing up.
- Loosely insert two M8 x 20 Machine Screws (H2) through the Lower Crossbar End holes and into the Leg Assembly, but do not tighten them yet.
- Once both screws have been inserted, tighten them using the 5mm Allen Wrench (H6).
- Repeat this step for the Left Leg Assembly (P1L) and second Lower Crossbar End.

Step 4 - Leg Assembly Attachment (Right Side)

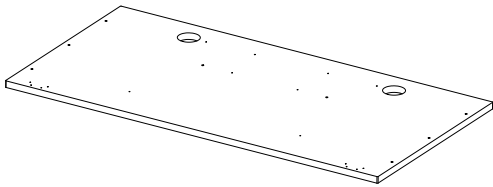

Use the holes shown circled in this image for attaching to tabletops that are 24" deep:

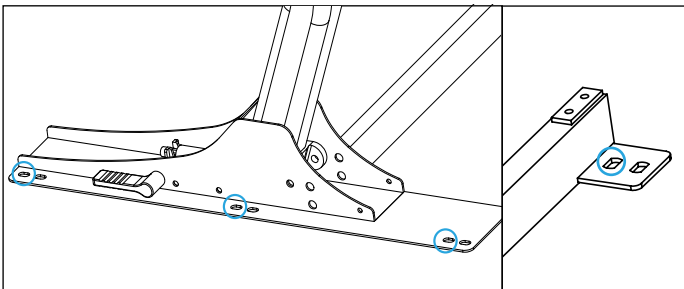

Use the holes shown circled in this image for attaching to tabletops that are 30" deep:

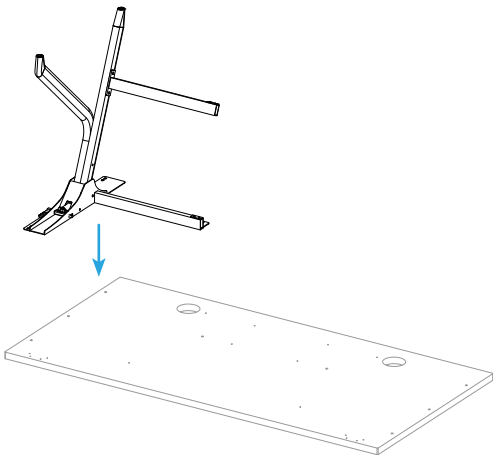
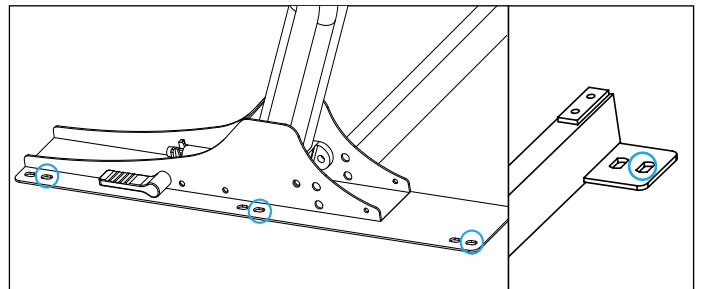

- Place the Right Leg Assembly onto the side of the tabletop as shown. This will be the right side of the table when it is flipped upright. When positioning a Leg Assembly on your tabletop, lift it up to move it instead of sliding it to avoid scratching. Align the holes determined above with the holes in the desktop that have metal threaded inserts installed.

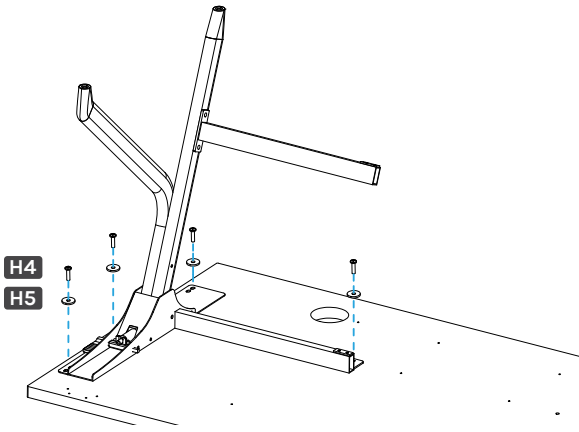

- D. Loosely insert four #10-24 x 3/4" Machine Screws (H4) and #10 Flat Washers (H5) through the frame holes and into the four metal threaded inserts in the tabletop, but do not tighten them yet.
- E. Confirm the correct holes were used per the following images:

Screw attachment location on 24" deep tabletop:

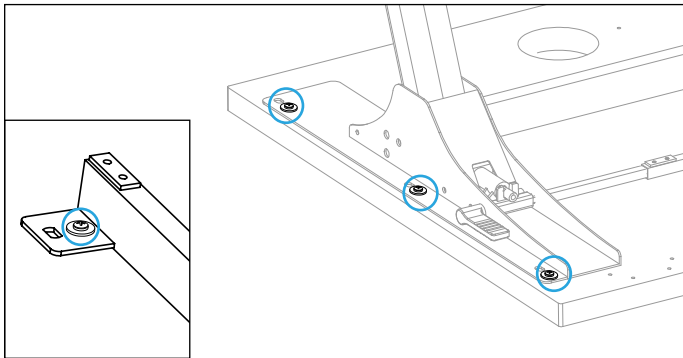

Screw attachment location on 30" deep tabletop:

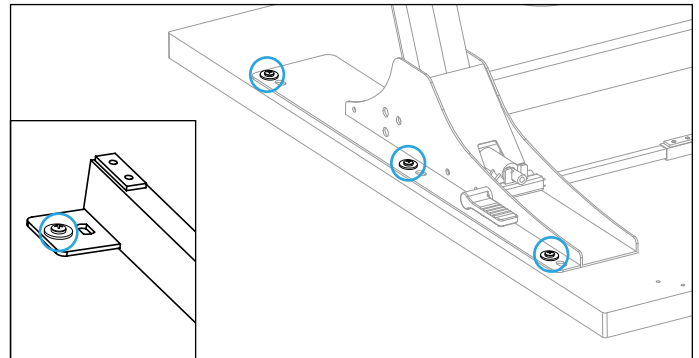

Center indicator hole

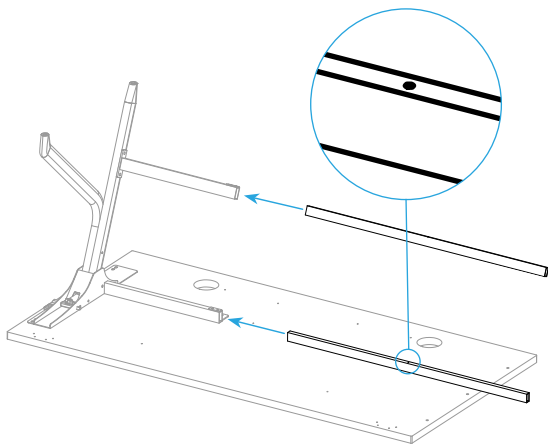

Step 5 - Crossbar Rail Installation

- A. Orient the Crossbar Rails (P4) so the center indicator holes are facing up and away from the tabletop.
- B. Slide one Crossbar Rail into the Right Upper Crossbar End (P2R) and the other into the Lower Crossbar End of the Right Leg Assembly (P1R).

Step 6 - Leg Assembly Attachment (Left Side)

- A. Slide the Upper Crossbar End (P2L) and Lower Crossbar End (P3) of the Left Leg Assembly (P1L) onto the ends of the two Crossbar Rails (P4) as shown.

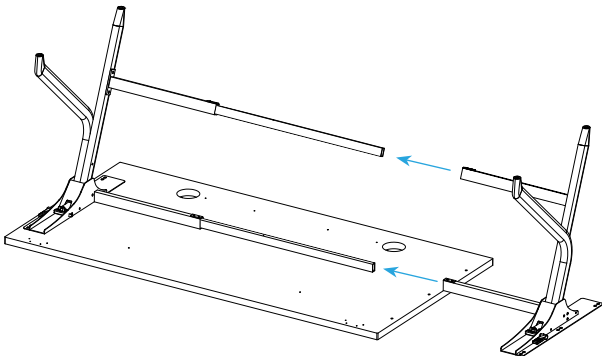

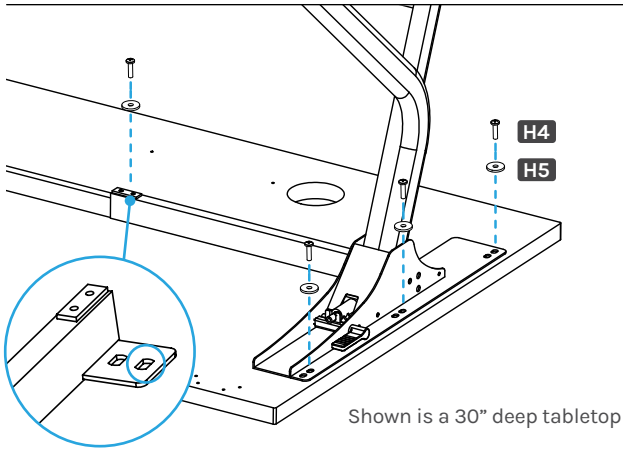

- B. Align the holes in the Left Leg Assembly with the metal threaded inserts in the tabletop.
- C. Loosely insert four #10-24 x 3/4" Machine Screws (H4) and #10 Flat Washers (H5) through the frame holes and into the four metal threaded inserts in the tabletop.
- D. Now that all eight screws have been inserted, tighten all of them (four screws on each side). Be careful to avoid stripping by not overtightening.

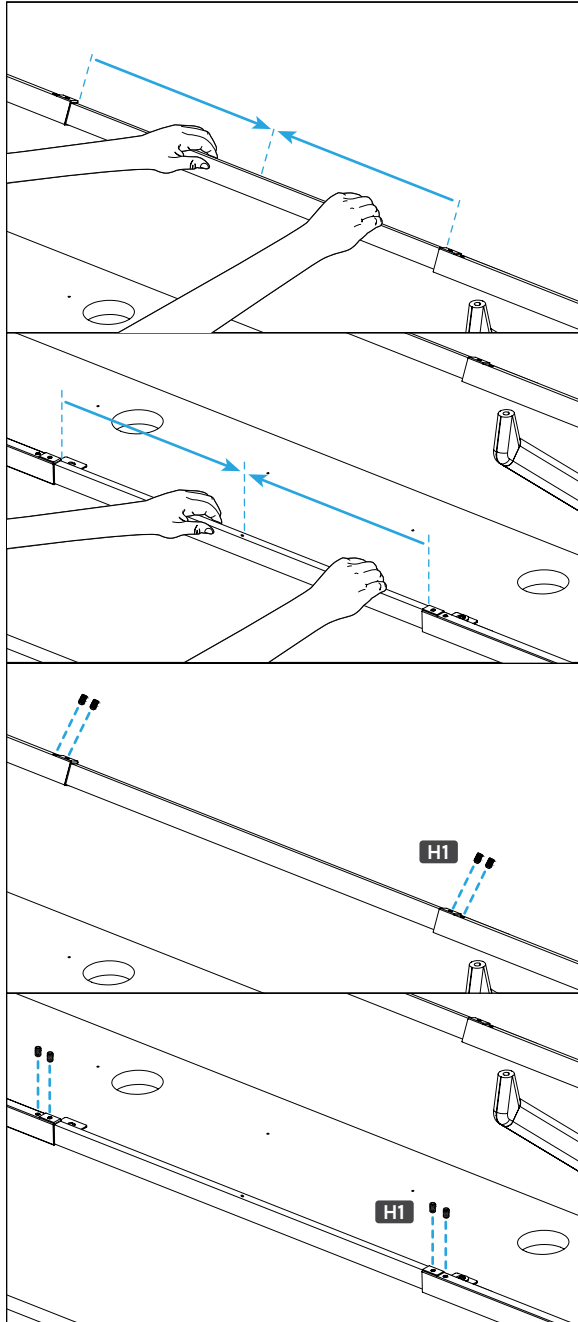

Step 7 - Crossbar Rail Positioning

- A. Slide each Crossbar Rail (P4) left or right until the center indicator holes are approximately centered between the two Upper Crossbar Ends and the two Lower Crossbar Ends.
- B. Insert the M6 x 10 Set Screws (H1) into each of the holes in the Upper and Lower Crossbar Ends and tighten them using the 3mm Allen Wrench (H7).

Step 8 - Latch Release Crossbar Installation

- A. Slide a Latch Release Crossbar End (P5) onto each end of the Latch Release Crossbar Rail (P6) with the holes on all three parts aligned to the same side. Holes on the ends of the two Latch Release Crossbar Ends for the M6 x 10 Set Screws (H1, circled) should be facing the same sides as shown.

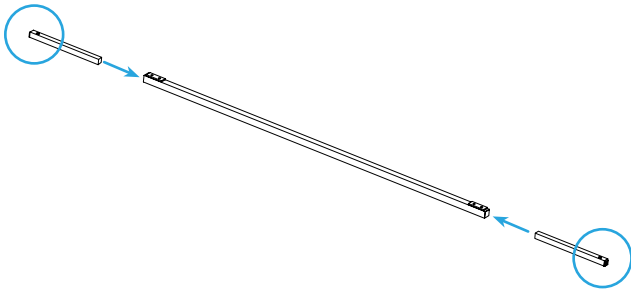

- B. Slide the Latch Release Crossbar Ends together, just enough for the assembly to fit between the two Leg Assemblies as shown.

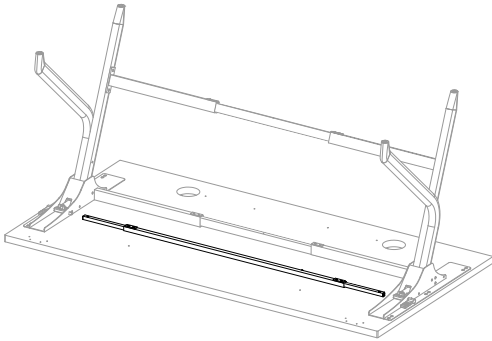

- C. Slide one of the Latch Release Crossbar Ends onto the square latch release handle post with the hole facing up as shown.

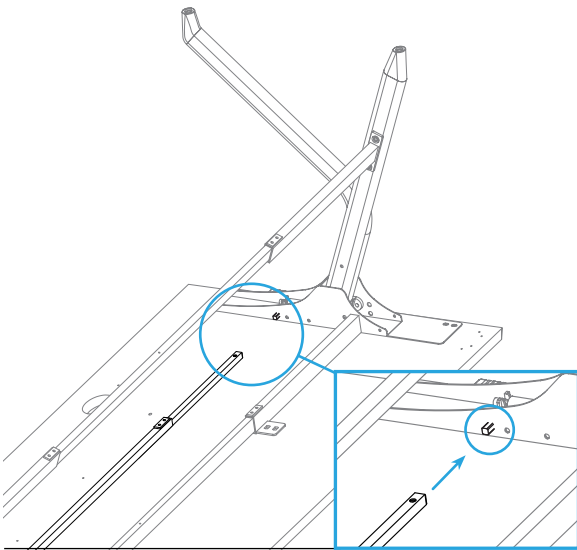

- D. Position the Latch Release Crossbar End approximately $\frac{3}{8}$ " (10mm) away from the inside of the Leg Assembly bracket. Insert one M6 x 10mm Set Screw (H1) in the hole and tighten using the 3mm Allen Wrench.

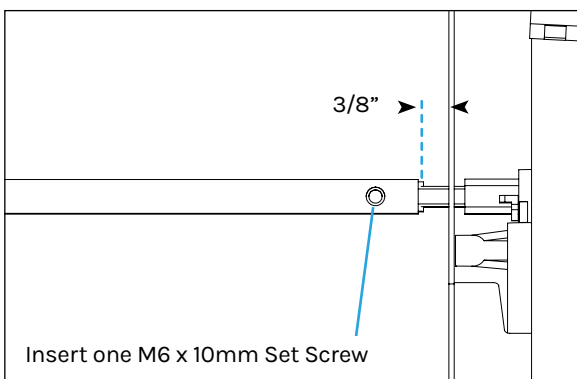

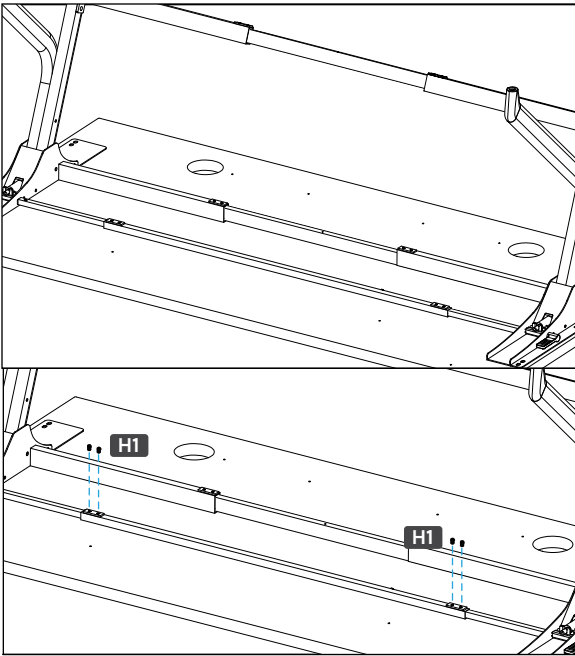

- E. Repeat previous two steps to attach the other Latch Release Crossbar End to the opposite Leg Assembly.
- F. Slide the Latch Release Crossbar Rail left or right as needed until it is approximately centered between the two Leg Assemblies as shown.

- G. Insert four M6 x 10 Set Screws (H1) into the Latch Release Crossbar Rail and tighten using the 3mm Allen Wrench (H7).

Step 9 - Caster Installation

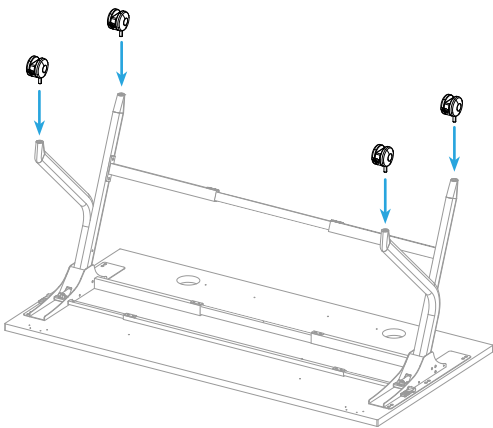

- A. Insert each of the Casters (P7) into the ends of the four legs of the Leg Assemblies.
- B. Tighten the Casters with the included Flat Wrench (H8).

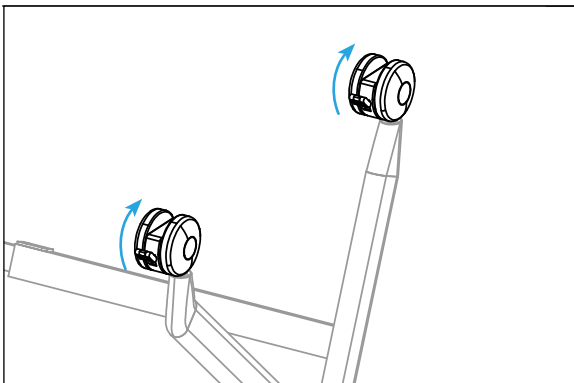

Step 10 - Turning the Flip Top Table Upright

- A. Flip the lever on each of the Casters (P7) to lock them for safety and ensure they do not roll. Test each Caster to make sure it's locked properly and does not turn.
- B. **IMPORTANT:** To prevent the table from folding while being flipped over, ensure the release levers on the Leg Assemblies are latched so the legs are locked in the upright position as shown.

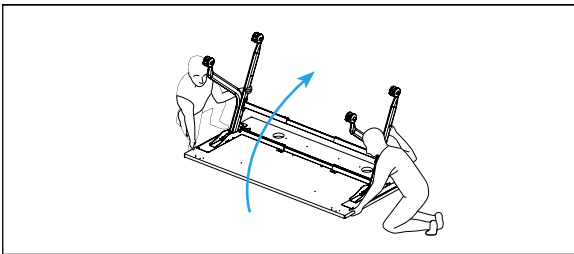

- C. With one person located at each end of the table, support the table frame and the tabletop equally and begin to tilt it slowly towards the back of the table.
- D. Readjust your grip and continue to rotate the table until it is upright with the Casters on the floor.
- E. Unlock the Casters and move the table to the desired location.
- F. Lock the Casters again to keep the table from moving while in use.

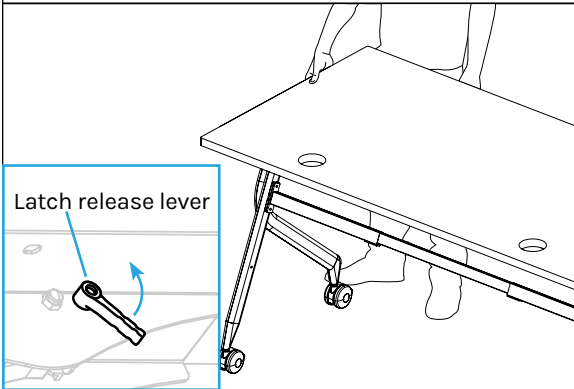
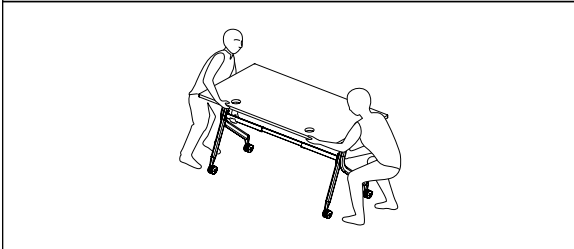

Step 11 - Flipping Tabletop Up

- A. When the table is not in use, the tabletop can be flipped up for storage.
- B. Depress the latch release lever on either leg assembly and gently lift the front edge of the tabletop until the back edge is resting gently on the back of the Leg Assemblies as shown.

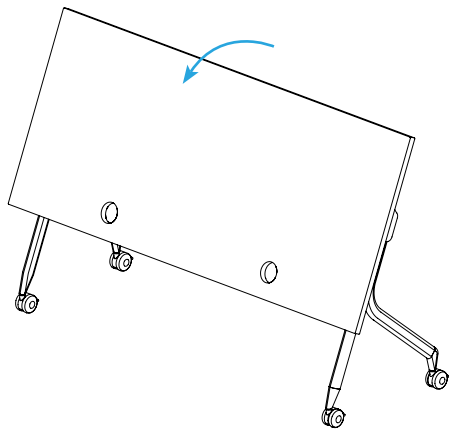

- C. To return the tabletop to its original position, pull the front edge of the tabletop down until you hear and feel the spring-loaded latches on each Leg Assembly engage. Gently lift up to ensure the tabletop is locked in place.

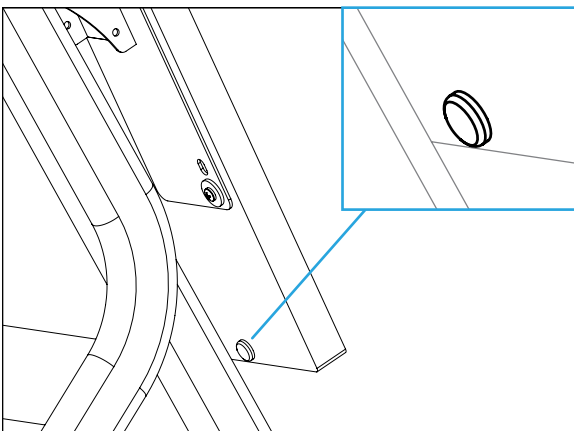

Step 12 - Rubber Bumper Installation

The Rubber Bumpers (H9) prevent damage from contact between the underside of the tabletop and the Leg Assemblies.

- A. With the tabletop flipped up, locate where the tabletop makes contact with each Leg Assembly.
- B. Remove the backing on each Rubber Bumper and press it firmly for 20 to 30 seconds onto the bottom side of the tabletop where it makes contact with one of the Leg Assemblies.

Nested Table Gangs

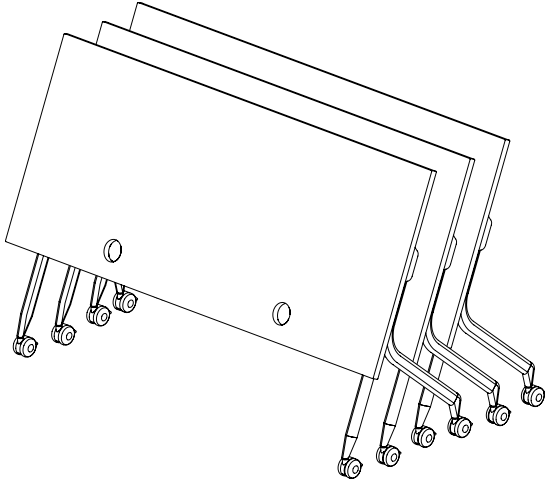

For compact storage, multiple tables can be “nested” as shown. Refer to instructions provided with the Flip Top Table Ganging Brackets (FRM069) if you purchased those and are planning to “gang” multiple tables together to keep them from becoming separated.

UPLIFT DESK[®]

Work Better. Live Healthier

[upliftdesk.com](https://www.upliftdesk.com)

info@upliftdesk.com

800-349-3839

512-614-3152

SAVE THE INSTRUCTIONS

Study this manual carefully. If this product is sold, please provide this manual to the buyer, installers, or support personnel operating the product.



Copyright Notice: This guide is a component of this UPLIFT Desk product. This guide is a part of the scope of delivery, even if the item is resold. This guide is also available on the UPLIFT Desk website: [upliftdesk.com](https://www.upliftdesk.com). These specifications are subject to United States copyright law.